

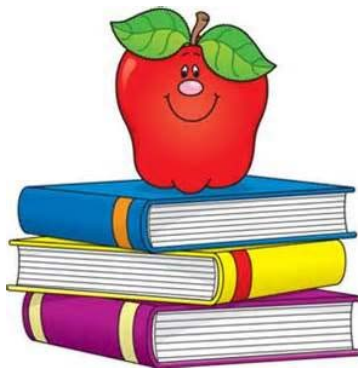

SAUSD
Distance Learning/ Aprendizaje a
distancia
Packet/ Paquete #2
(7 weeks of learning)
(7 semanas de aprendizaje)
Kindergarten
2020



SAUSD Distance Learning/ Aprendizaje a distancia - Kindergarten

This packet provides your child with ways to continue to develop their learning at home. It is recommended that Kinder students complete 3-4 activities from the packet a day. Parents may choose activities from the different sections of the packet to fit with the daily schedule at home. Kinder students also need time each day for quiet time, playtime, and physical activity.

Este paquete brinda a su hijo/a maneras para continuar desarrollando su aprendizaje en casa. Se recomienda que los alumnos de Kinder realicen 3 a 4 actividades del paquete por día. Los padres pueden escoger actividades de las diferentes secciones del paquete, de acuerdo con el itinerario diario en casa. Los alumnos de Kinder también necesitan tiempo cada día para tiempo en silencio, tiempo de juego y actividad física.

Build Language/ Construya lenguaje	Pg. 1
Read Together/ Lean juntos	Pg. 19
Journal Writing/ Escribir en un diario	Pg. 37
Penmanship/ El arte de escribir	Pg. 91
Phonics and HFW/Fonética y palabras de uso frecuente	Pg. 125



Build Language/ Construya lenguaje

Kinder students benefit from practicing their language. The following are some suggested activities for building language. Building language can be done in either English or Spanish.

Los alumnos de Kinder se benefician de practicar el lenguaje. A continuación, hay algunas actividades sugeridas para construir lenguaje. Construir lenguaje se puede hacer en inglés o en español.

Describe Five!

Have your child find an object that he can see in the room or yard, but tell him not to say the name of the object. Then have him think of five words that tell something about the object, and see if you can guess what it is. For example, if he is looking at a red ball he can say, **red, round, bounces, squishy, toy**. Or if he is thinking of a tree, he might say, **brown, green, bark, leaves, tall**. This is also a good activity to play with another child.

Challenge: Once you have guessed the object, have your child draw its picture and you or your child can write the describing words and hang it in his room.

Your child is learning to use words to describe things.

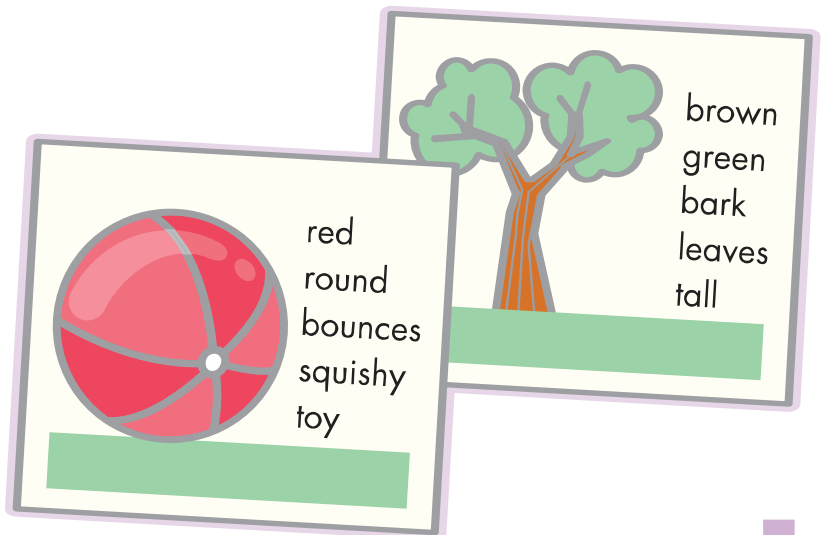

¡Descríbelo con Cinco Palabras!

Pídale a su hijo que busque un objeto que pueda ver en la habitación o en el jardín, pero pídale que no le diga qué objeto es. Pídale que piense en cinco palabras que describan algo del objeto e intente adivinar qué es. Por ejemplo, si está mirando una pelota roja puede decir, **roja, redonda, rebota, esponjosa, juguete.** O si está pensando en un árbol, puede decir, **marrón, verde, corteza, hojas, alto.** Esta también es una buena actividad para jugar con otro niño.

Desafío: una vez que adivine qué objeto es, pídale a su hijo que lo dibuje y usted o su hijo pueden escribir las palabras que lo describan y colgar el dibujo en su habitación.

Su hijo está aprendiendo a usar palabras para describir objetos.

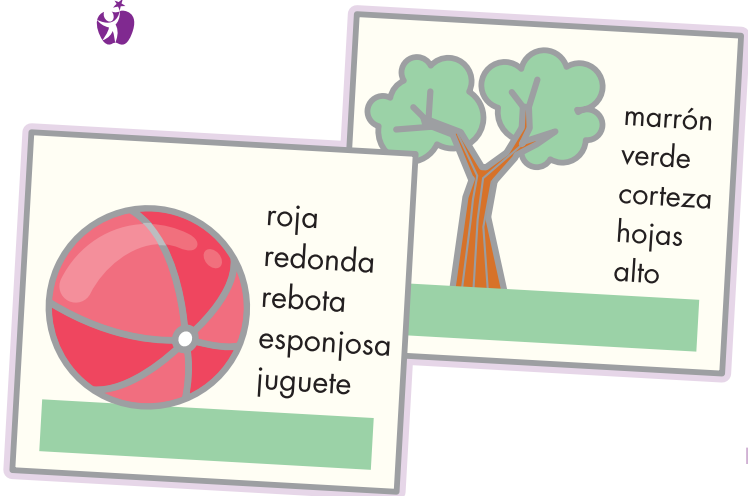

I Can Help

Find ways that your child can help you or others around you. Praise his work by saying something like, **You are so helpful! Thank you so much for...**

At this age, your child has many skills that are very useful! He is able to carry things, find things, clean up, set the table, and help with simple chores around the house.

Challenge: Think of some simple jobs that your child can have to help out around the house like feeding the cat, setting the table, or picking up the baby's toys. Let him know how much it helps the family when he helps out!

Your child is learning to work as part of a team. He is learning that he is a valuable and helpful member of the family.

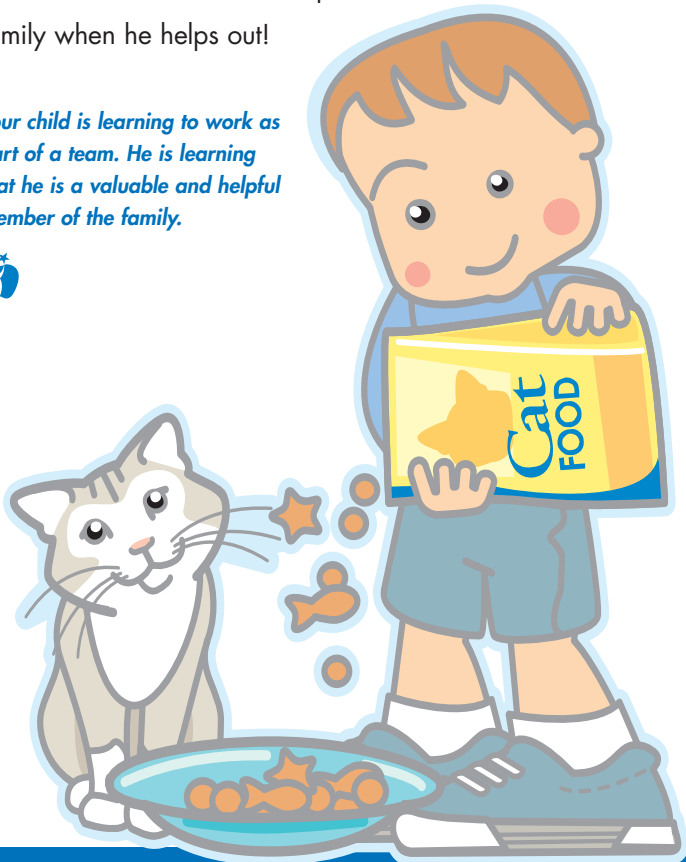

Puedo Ayudar

Busque formas en que su hijo pueda ayudarlo a usted o a otras personas cercanas. Felicítelo por su trabajo y dígale algo como, **¡Eres muy amable!**

Muchas gracias por... ¡A esta edad, su hijo tiene muchas habilidades muy útiles! Puede transportar objetos, encontrar objetos, ordenar, poner la mesa y ayudar con tareas simples en el hogar.

Desafío: Piense en trabajos simples que su hijo puede hacer para ayudar en el hogar, como alimentar al gato, poner la mesa o recoger los juguetes del bebé. ¡Hágale saber lo mucho que ayuda a la familia cuando él colabora!

Su hijo está aprendiendo a trabajar en equipo. Está aprendiendo que es un integrante valioso y útil de la familia.



I Spy...

Did you ever play this game as a child? Look around you and choose an item that you **spy**. Say, **I spy, with my little eye, something beginning with the letter "M" (or any other letter)**. Make the sound of the letter, **The letter M makes the sound Mmm, Mmm. Do you see something that starts with an "Mmm" sound?** This is a great game to play in the car, on a walk, or even when you are stuck in line at the grocery store!

Challenge: Have your child **Spy with his little eye** and have you guess!

You child is learning that every letter makes a sound. He is learning to listen for beginning sounds in words which will help him as he learns to read.

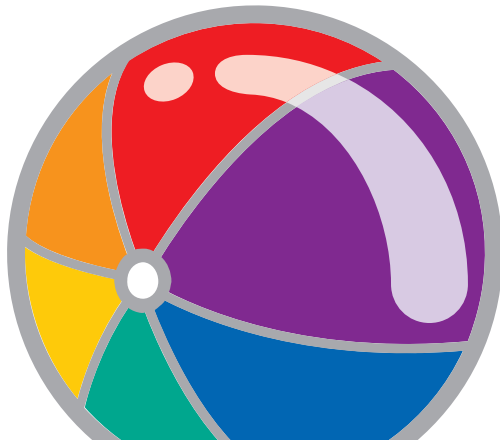

Veó, Veó

Jugó alguna vez este juego de niño? Mire a su alrededor y elija un objeto que “vea”. Diga, **Veó, veó** y el niño tiene que responder: **¿Qué ves?, luego diga: Una cosita... con la letrita “M” (o con cualquier otra letra).** Reproduzca el sonido de la letra **La letra M suena Mmm, Mmm. ¿Ves algo que empiece con el sonido “Mmm”?** Éste es un juego genial para jugar en el automóvil, o mientras pasean, ¡o incluso cuando están haciendo fila en la tienda!

Desafío: ¡Pídale a su hijo que juegue al **Veó veó** para que usted trate de adivinar!

Su hijo está aprendiendo que cada letra tiene un sonido. Está aprendiendo a escuchar los sonidos con los que empiezan las palabras, que lo ayudarán cuando aprenda a leer.

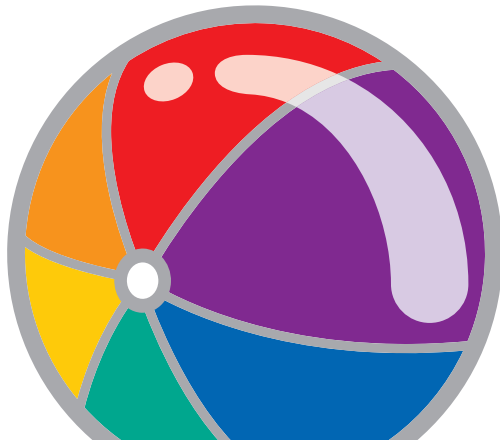

I'm Listening

When your child is talking to you, try and make eye-contact and show her that you are really listening to what she is saying. Ask her questions to help her tell her story, such as:

And then what happened? or

What did he say?

Let her know that you are interested in her ideas and that her feelings are important to you, by responding with statements like:

That must have hurt or

You seem excited about that!

Challenge: When your child tells a good story, ask her to repeat it for someone else. Set it up with a statement like, **That is such a great story! I think Mom would like to hear about this too!**

Your child is learning to express herself. She is also learning that she is a very important person with valuable ideas to share.



Te Escucho

Cuando su hijo le hable, intente hacer contacto visual y muéstrole que realmente está escuchando lo que le dice. Hágale preguntas para ayudarle a contar su historia, cómo

¿Y luego qué pasó? o

¿Qué dijo?.

Hágale saber que está interesada en sus ideas y que sus sentimientos son importantes para usted, respondiendo frases como,

Eso debe haberte dolido o

¡Pareces entusiasmado con eso!

Desafío: Cuando su hijo cuente una buena historia, pídale que se la repita a alguien más. Comience con una frase como, **¡Esa es una historia genial!**

¡Creo que a Papá también le gustaría oír esto!

Su hijo está aprendiendo a expresarse. También está aprendiendo que es una persona muy importante con ideas valiosas para compartir.



Make a List

Do you have a lot of things to do each day? You can involve your child in the process of getting them done...and strengthen her pre-reading skills! Sit down at the table with your child and tell her that you need to make a list. It doesn't matter what type of list it is, it can be a list of things that you need to do around the house, a list for the grocery store, or a list of errands. As you write the list, speak and write slowly and clearly, and sound out each of the letters aloud as you write them. Number the items on the list. Take this list with you as you and your child go through the day. Cross off items that you have finished. Ask your child to help you remember!

Challenge: Have your child find the items and cross them off herself. You may need to give her hints, **Butter starts with a "Buh" sound, so you are looking for a word that starts with a "B."**

Your child is learning that words are useful tools that can help us every day. She is also learning how letters are formed and how words are written.



Haz una Lista

Tiene muchas cosas para hacer cada día? Puede hacer participar a su hijo en el proceso de llevarlas a cabo... ¡y fortalecer sus habilidades para dar sus primeros pasos en la lectura! Siéntese a la mesa con su hijo y dígame que necesita hacer una lista. No importa el tipo de lista, puede ser una lista de cosas que necesita hacer en la casa, una lista para la tienda o una lista de recados. Mientras hace la lista, hable y escriba lentamente y en forma clara, y diga en voz alta cada letra a medida que las escribe. Enumere los puntos de la lista. Lleve la lista con usted mientras pasa el día con su hijo. Tache los puntos que haya completado. ¡Pídale a su hijo que le ayude a recordar!

Desafío: Pídale a su hijo que encuentre los puntos y los tache. Es posible que deba darle pistas, **Mantequilla empieza con sonido "Ma", así que debes buscar una palabra que comience con la "M".**

Su hijo está aprendiendo que las palabras son herramientas útiles que nos ayudan a diario. También está aprendiendo cómo se forman las letras y se escriben las palabras.



A Memory Game

Take a kitchen tray or box lid that will hold several items in plain view. Find five toys or objects that your child is familiar with. For example, put onto the tray a crayon, keys, an apple, a toy car and a spoon. Show your child all of the toys, and tell her you are going to take one item away while she is not looking and have her guess which one you took away. Let her look at all of the toys on the tray for a minute. Then have her cover her eyes or look away while you remove one item. Hide the item behind your back and let her look at the tray again. See if she can guess which item you took away. You can make this game harder by starting with more items. Let your child put several items on the tray and play the game with you guessing which item she removed.

Challenge: Take away more than one item for your child to guess! See if she can remember two or three missing items at a time.

Your child is learning social skills when she learns to play a game with you, following rules and taking turns. When she guesses the right item that you took away, it builds her self-confidence.



Juego de la Memoria

Tome una bandeja de la cocina o la tapa de una caja que pueda contener varios objetos a simple vista. Busque cinco juguetes u objetos con los que su hijo esté familiarizado. Por ejemplo, coloque en la bandeja una crayola, un juego de llaves, una manzana, un auto de juguete y una cuchara. Muéstrole a su hijo todos los juguetes y dígame que quitará un objeto mientras él no mira, y déjelo adivinar cuál es. Deje que mire todos los juguetes que hay en la bandeja durante un minuto. Luego dígame que se cubra los ojos o que mire hacia otro lado mientras retira un objeto. Esconda el objeto detrás de su espalda y deje que mire nuevamente la bandeja. Observe si puede adivinar cuál es el objeto que usted quitó. Puede hacer que este juego sea más difícil si utiliza más objetos. Deje que su hijo coloque varios objetos en la bandeja y juegue con él adivinando cuál es el objeto que él quitó.

Desafío: ¡Retire más de un objeto para que su hijo adivine! Vea si puede recordar dos o tres objetos faltantes al mismo tiempo.

Su hijo está aprendiendo habilidades sociales mientras aprende a jugar con usted, siguiendo reglas y esperando su turno. Adivinar el objeto correcto que usted quita, estimula su confianza en sí mismo.



Story Sharing

You can make up stories with your child by letting her fill in words as you go along. For example, start by saying, **Once upon a time, there was a family who lived in a _____** and let your child fill in a word. Then keep going with the story. **Here is who was in the family: a mother, and who else? _____.** **This family decided to go on a trip to _____.** And continue like this, letting your child make the story similar to real life, or a silly make-believe story. You can ask several children to take turns adding to the story.

Challenge: Let your child make up the whole story. Write down her words and read her story back to her. Let her draw pictures to go with the story if she wants. Have another person read her story, too.

Telling stories with your child will help her learn about words, language and listening.



Compartir Cuentos

Puede inventar cuentos con su hijo dejándolo completar la historia con palabras a medida que usted lo cuenta. Por ejemplo, comience diciendo, **Había una vez, una familia que vivía en un _____**, y deje que su hijo complete la oración con una palabra. Luego continúe con el cuento. **La familia estaba formada por: una mamá, ¿y quién más? _____**. **Esta familia decidió irse de viaje a _____**. Y siga así, dejando que su hijo arme una historia similar a la vida real, o un cuento divertido de fantasía. Puede pedirle a varios niños que agreguen partes al cuento por turnos.

Desafío: deje que su hijo invente todo el cuento. Anote sus palabras y luego, léale el cuento. Deje que haga dibujos acerca del cuento si quiere. Pídale a otra persona que también lea el cuento.

Contar cuentos con su hijo le permitirá aprender palabras, el lenguaje y a escuchar.



Laundry Helper

The next time you take clean laundry out of the dryer, have your child help you sort! You can make piles for each member of your family before you fold. Or you can make piles of shirts, pants, towels, and so on. Talk about the sizes as you separate:

**This is a little shirt,
whose shirt do you think it is?**

Have your child find the matches for socks and put them together. Give her ideas for what to look for, for example:

**This sock has green stitching,
can you find its match?**

For a change, sing a made-up song together about the clothing, such as:

**This is the red sock that matches the
red sock. Together we have a pair!**

Challenge: Have your child help you fold the clothes and put them neatly into stacks. Then, have her put them away in the proper places.

Your child is learning to sort items by size or color. She is also learning that she is a valuable helper in the home.



Asistente para Lavar la Ropa

La próxima vez que saque la ropa limpia de la secadora, ¡invite a su hijo a que le ayude a separarla! Pueden hacer montones para cada miembro de la familia antes de doblar la ropa. O pueden hacer montones de camisas, pantalones, toallas, y así sucesivamente. Platique acerca de los tamaños mientras separan la ropa:

**Esta es una camisa pequeña,
¿de quién crees que es?**

Haga que su hijo busque los dos calcetines de cada par y los ponga juntos. Dele ideas acerca de qué debe buscar, por ejemplo:

**Este calcetín tiene costuras verdes,
¿puedes encontrar el otro?**

Para darle un toque original, cante una canción inventada por los dos sobre la ropa, por ejemplo:

**Éste es el calcetín rojo que va con
el otro calcetín. ¡Juntos forman un par!**

Desafío: haga que su hijo le ayude a doblar la ropa y a ponerla en montones en forma ordenada. Luego, haga que la guarde en los lugares correctos.

Su hijo está aprendiendo a separar objetos por tamaño o color. Además está aprendiendo que puede ser una valiosa ayuda para el hogar.





Read Together/ Lean juntos

Read a book with your child. Read aloud activities have been included. Use the provided reading log to list the books you read together.

Lea un libro con su hijo/a. Se han incluido actividades para leer en voz alta. Use el registro de lectura en el paquete para llevar una lista de los libros que lean juntos.

Read to Me

Find a time in your daily routine when you can read to your child. Before bed? After dinner? Have your child sit close to you so that you can both see the pictures and words. As you read, run your finger under the words. Experiment with changing your voice to sound like the characters in the story. At this age, your child should enjoy books that have a few sentences on each page, and may like you to read each book many times.

Each time you read the same story, expect slightly more from your child. For example, with the story of The Three Little Pigs, ask **Do you remember how the story ended for the wolf?** Continue with questions that help your child to use her own words like, **What do you think is happening on this page?** Ask questions that relate the story to your child's life, such as **How would you feel if the house you built was blown over?**

Your child is learning to love reading and that it is an important part of each day. This will prepare her for daily homework in school and will help her to be a better reader.



Léeme

Encuentre un momento en su rutina diaria en el que pueda leer con su hijo. ¿Antes de dormir? ¿Después de la cena? Siente a su hijo cerca para que ambos puedan ver las imágenes y las palabras. A medida que lea, recorra con el dedo lo que va leyendo. Trate cambiando su voz para que parezca la voz de los personajes del cuento. A esta edad, su hijo seguramente disfruta de los libros que tienen algunas oraciones en cada página, y es posible que quiera que le lea cada libro varias veces.

Cada vez que lea el mismo cuento, puede esperar algo más de su hijo. Por ejemplo, con el cuento de Los tres cochinitos, pregúntele **¿Recuerdas como terminaba la historia para el lobo?** Continúe con preguntas que ayuden a su hijo a usar sus palabras como, **¿Qué crees que ocurre en esta página?** Hágale preguntas que relacionen el cuento con la vida de su hijo, tales como **¿Cómo te sentirías si la casa que construyeras fuera derribada?**

Desafío: Visite la biblioteca para elegir libros acerca de temas que le interesen a su hijo.

Su hijo está aprendiendo a disfrutar de la lectura y que es una parte importante de cada día. Esto lo preparará para su tarea diaria en la escuela y le ayudará a leer mejor.



A New Ending

Read a story with your child that she is familiar with, but tell her that you are going to make up a new ending together. Part way through the book, stop reading and ask your child if she knows how the story ends. Let her tell you in her own words the ending that is written in the book. Then ask if she can think of a different ending. If she needs help, ask her questions about how the story could be different. For example, **Do you think he has a dream while he is sleeping? What do you think he dreams about? What do you think he will do when he wakes up?** Let your child continue the story as long as she can, or keep asking questions to help her create a new ending.

Challenge: Write down the new ending that your child created, and have her draw pictures to go with it.

Making up a new ending to the story builds your child's imagination and her language skills.



Un Nuevo Final

Lea a su hijo una historia que le resulte conocida, pero dígame que van a inventar juntos un nuevo final. En alguna parte de la historia, deje de leer y pregúntele a su hijo si sabe cómo termina. Deje que le cuente con sus propias palabras el final que está escrito en el libro. Luego pregúntele si se le ocurre un final distinto. Si necesita ayuda, pregúntele cómo podría ser diferente la historia. Por ejemplo: **¿Pensas que el personaje tiene sueños mientras duerme? ¿Qué crees que está soñando? ¿Qué piensas que hará cuando se despierte?** Deje que su hijo siga con la historia durante todo el tiempo que pueda, o sígale haciendo preguntas para ayudarlo a inventar un nuevo final.



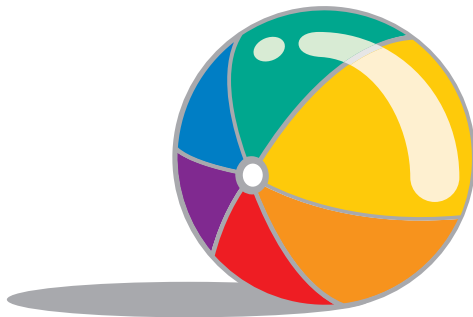

Desafío: escriba el nuevo final que inventó su hijo, y pídale que haga dibujos que lo ilustren.

Inventar un nuevo final para la historia estimula la imaginación de su hijo y sus habilidades con el lenguaje.

















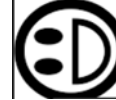

Reading Log Registro de lectura

**Nombre/
Name:** _____

Date/Fecha	Title/Título	My Book Rating/ Mi calificación del libro	Minutes read /Minutos leyendo	Parent or Guardian Signature/ Firma de padre o tutor
				
				
				
				





Reading Log Registro de lectura

**Nombre/
Name:** _____

Date/Fecha	Title/Título	My Book Rating/ Mi calificación del libro	Minutes read /Minutos leyendo	Parent or Guardian Signature/ Firma de padre o tutor
		   		
		   		
		   		
		   		















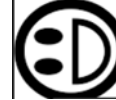

Reading Log Registro de lectura

**Nombre/
Name:** _____

Date/Fecha	Title/Título	My Book Rating/ Mi calificación del libro	Minutes read /Minutos leyendo	Parent or Guardian Signature/ Firma de padre o tutor
				
				
				
				















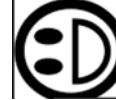

Reading Log Registro de lectura

**Nombre/
Name:** _____

Date/Fecha	Title/Título	My Book Rating/ Mi calificación del libro	Minutes read /Minutos leyendo	Parent or Guardian Signature/ Firma de padre o tutor
		   		
		   		
		   		
		   		

















Reading Log Registro de lectura

**Nombre/
Name:** _____

Date/Fecha	Title/Título	My Book Rating/ Mi calificación del libro	Minutes read /Minutos leyendo	Parent or Guardian Signature/ Firma de padre o tutor
		   		
		   		
		   		
		   		





Reading Log Registro de lectura

**Nombre/
Name:** _____

Date/Fecha	Title/Título	My Book Rating/ Mi calificación del libro	Minutes read /Minutos leyendo	Parent or Guardian Signature/ Firma de padre o tutor
		   		
		   		
		   		
		   		















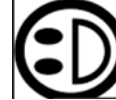

Reading Log Registro de lectura

**Nombre/
Name:** _____

Date/Fecha	Title/Título	My Book Rating/ Mi calificación del libro	Minutes read /Minutos leyendo	Parent or Guardian Signature/ Firma de padre o tutor
				
				
				
				















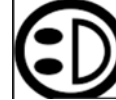

Reading Log Registro de lectura

**Nombre/
Name:** _____

Date/Fecha	Title/Título	My Book Rating/ Mi calificación del libro	Minutes read /Minutos leyendo	Parent or Guardian Signature/ Firma de padre o tutor
		   		
		   		
		   		
		   		















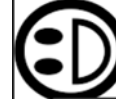

Reading Log Registro de lectura

**Nombre/
Name:** _____

Date/Fecha	Title/Título	My Book Rating/ Mi calificación del libro	Minutes read /Minutos leyendo	Parent or Guardian Signature/ Firma de padre o tutor
		   		
		   		
		   		
		   		















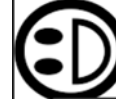

Reading Log Registro de lectura

**Nombre/
Name:** _____

Date/Fecha	Title/Título	My Book Rating/ Mi calificación del libro	Minutes read /Minutos leyendo	Parent or Guardian Signature/ Firma de padre o tutor
		   		
		   		
		   		
		   		















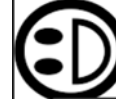

Reading Log Registro de lectura

**Nombre/
Name:** _____

Date/Fecha	Title/Título	My Book Rating/ Mi calificación del libro	Minutes read /Minutos leyendo	Parent or Guardian Signature/ Firma de padre o tutor
		   		
		   		
		   		
		   		

Reading Log Registro de lectura

**Nombre/
Name:** _____

Date/Fecha	Title/Título	My Book Rating/ Mi calificación del libro	Minutes read /Minutos leyendo	Parent or Guardian Signature/ Firma de padre o tutor
		   		
		   		
		   		
		   		



Journal Writing/ Escribir en un diario

Kindergarten Writing Journal

Use the writing paper to draw and write each day. You can draw and write about anything you would like. You can also pick from the ideas below if you need help.

Journal ideas:

Today I _____.

My favorite food is _____ because _____.

My favorite toy is _____ because _____.

At recess, I like to _____.

My best friend is _____ because _____.

At home, I like to _____.

I wish _____.

When I grow up _____.

My favorite book is _____ because _____.

On the weekends, I like to _____.

My favorite animal is _____ because _____.

The best thing about school is _____.

Kindergarten. Diario de escritura

Usa el papel de escribir que se encuentra al final de este cuadernillo para dibujar y escribir cada día. Puedes dibujar y escribir sobre lo que quieras. También puedes elegir entre las ideas que encuentras a continuación.

Ideas para el diario de escritura:

Algunas cosas que hice hoy son _____.

Mi comida favorita es _____ porque _____.

Mi juguete favorito es _____ porque _____.

En el recreo, me gusta _____ porque _____.

Mi mejor amigo es _____ porque _____.

En casa, me gusta _____ porque _____.

Yo deseo _____ porque _____.

Cuando sea grande _____ porque _____.

Mi libro favorito es _____ porque _____.

En los fines de semana me gusta _____.

Mi animal favorito es _____ porque _____.

Lo mejor de la escuela es _____ porque _____.

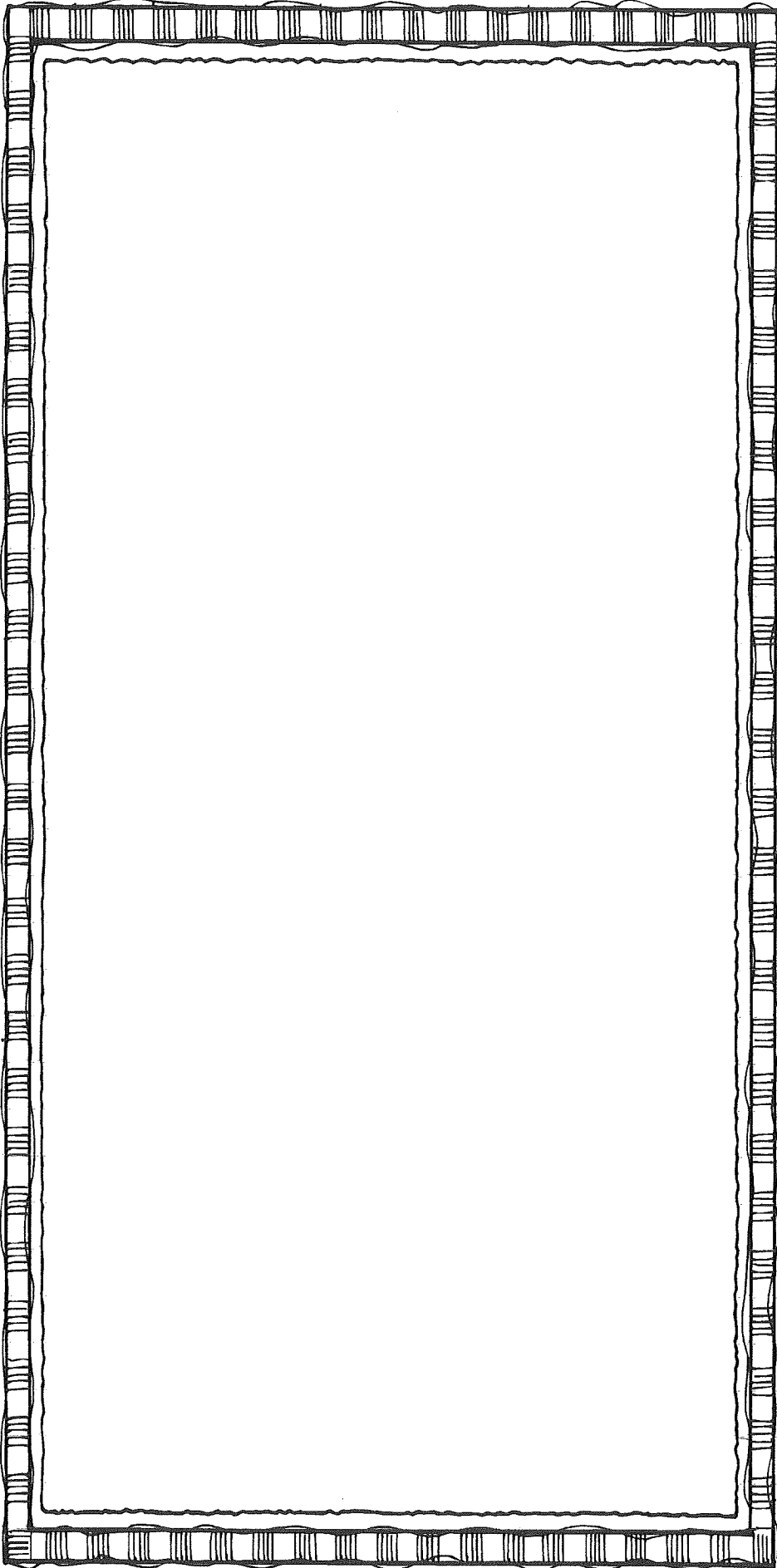

Handwriting practice lines consisting of four sets of horizontal lines. Each set includes a solid top line, a dashed middle line, and a solid bottom line, providing a guide for letter height and placement.

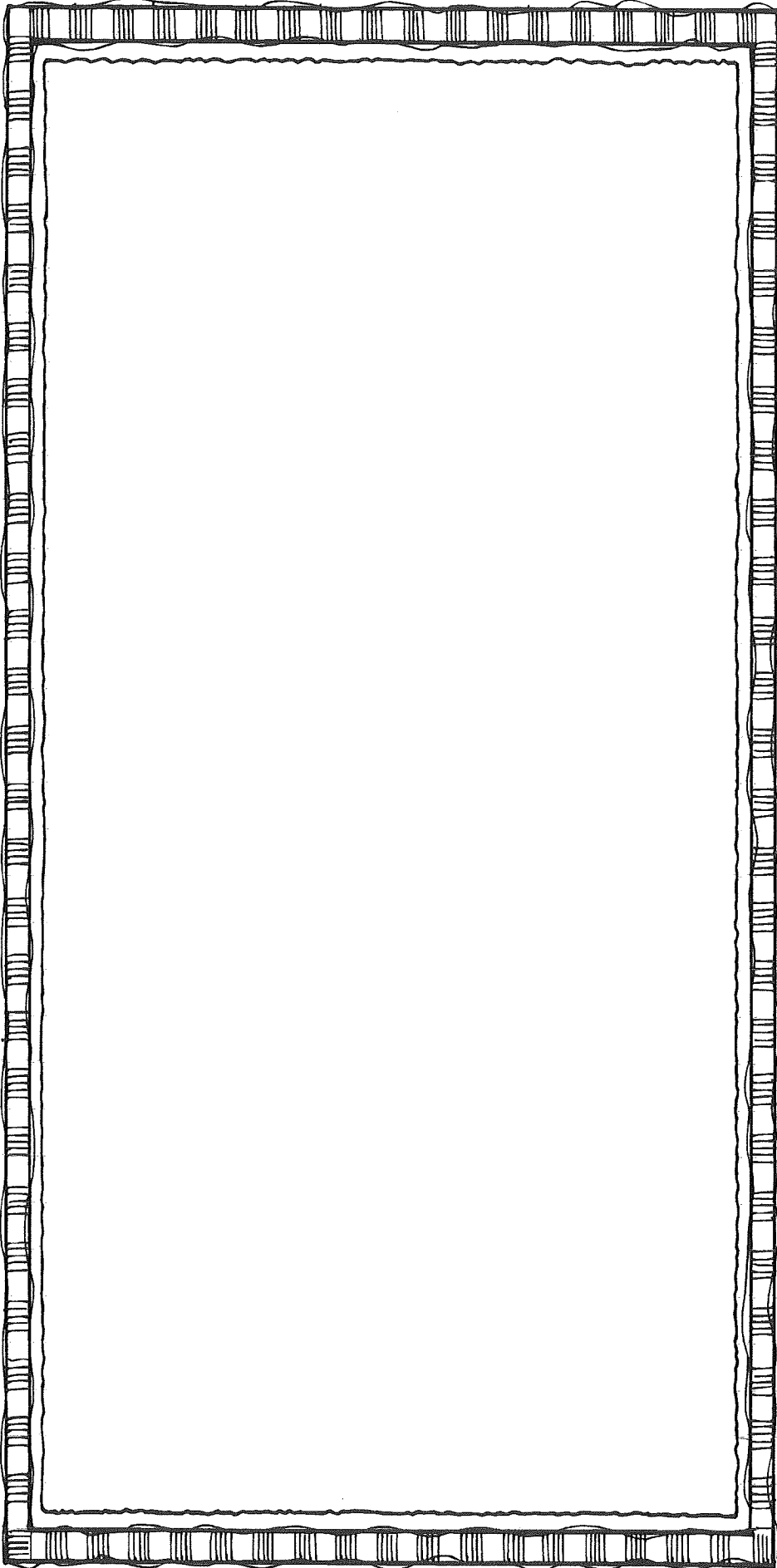

Handwriting practice lines consisting of four sets of horizontal lines. Each set includes a solid top line, a dashed middle line, and a solid bottom line, providing a guide for letter height and placement.

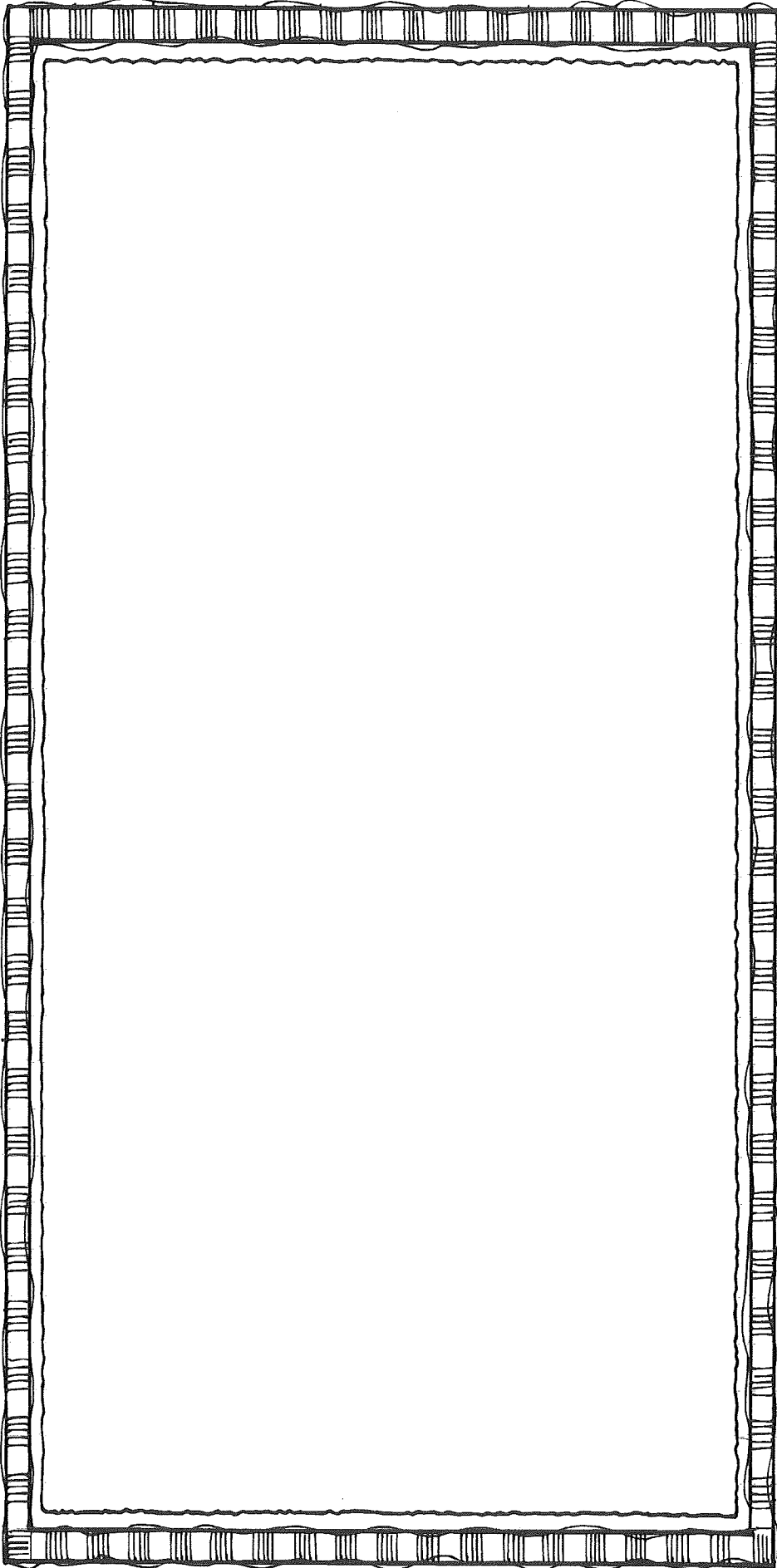

Handwriting practice lines consisting of four sets of horizontal lines. Each set includes a solid top line, a dashed middle line, and a solid bottom line, providing a guide for letter height and placement.

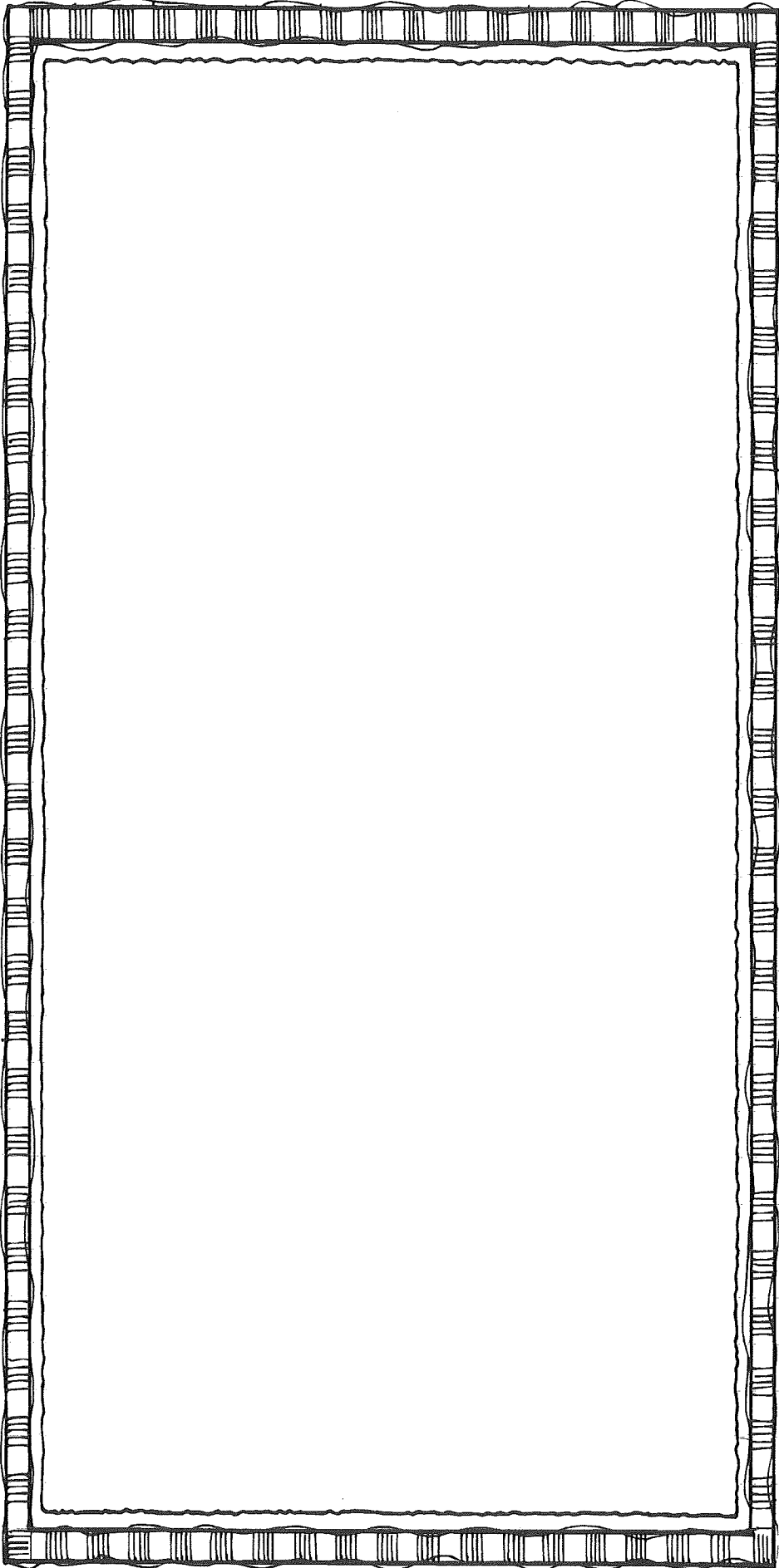

Handwriting practice lines consisting of four sets of horizontal lines. Each set includes a solid top line, a dashed middle line, and a solid bottom line, providing a guide for letter height and placement.

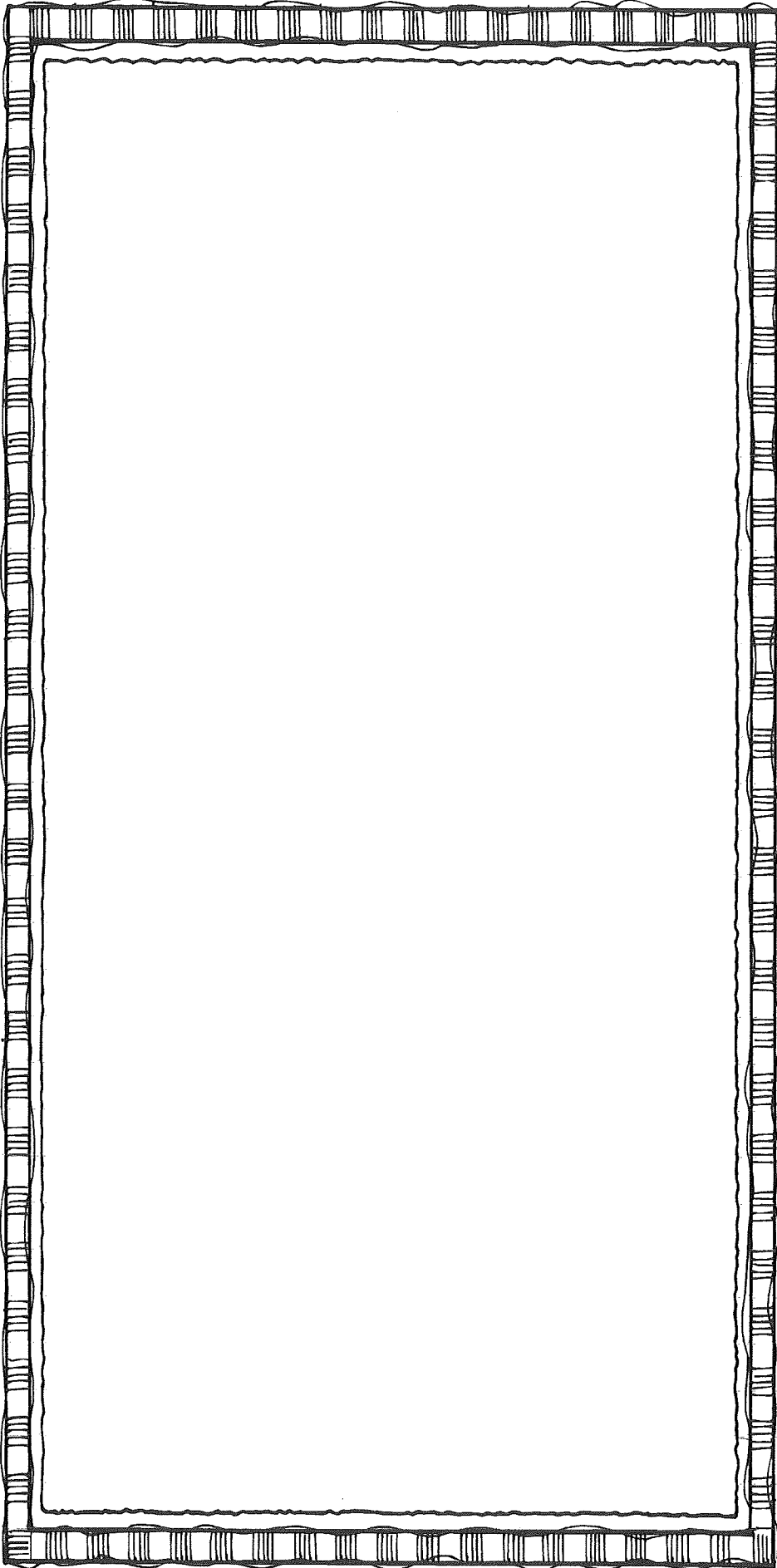

Handwriting practice lines consisting of four sets of horizontal lines. Each set includes a solid top line, a dashed middle line, and a solid bottom line.

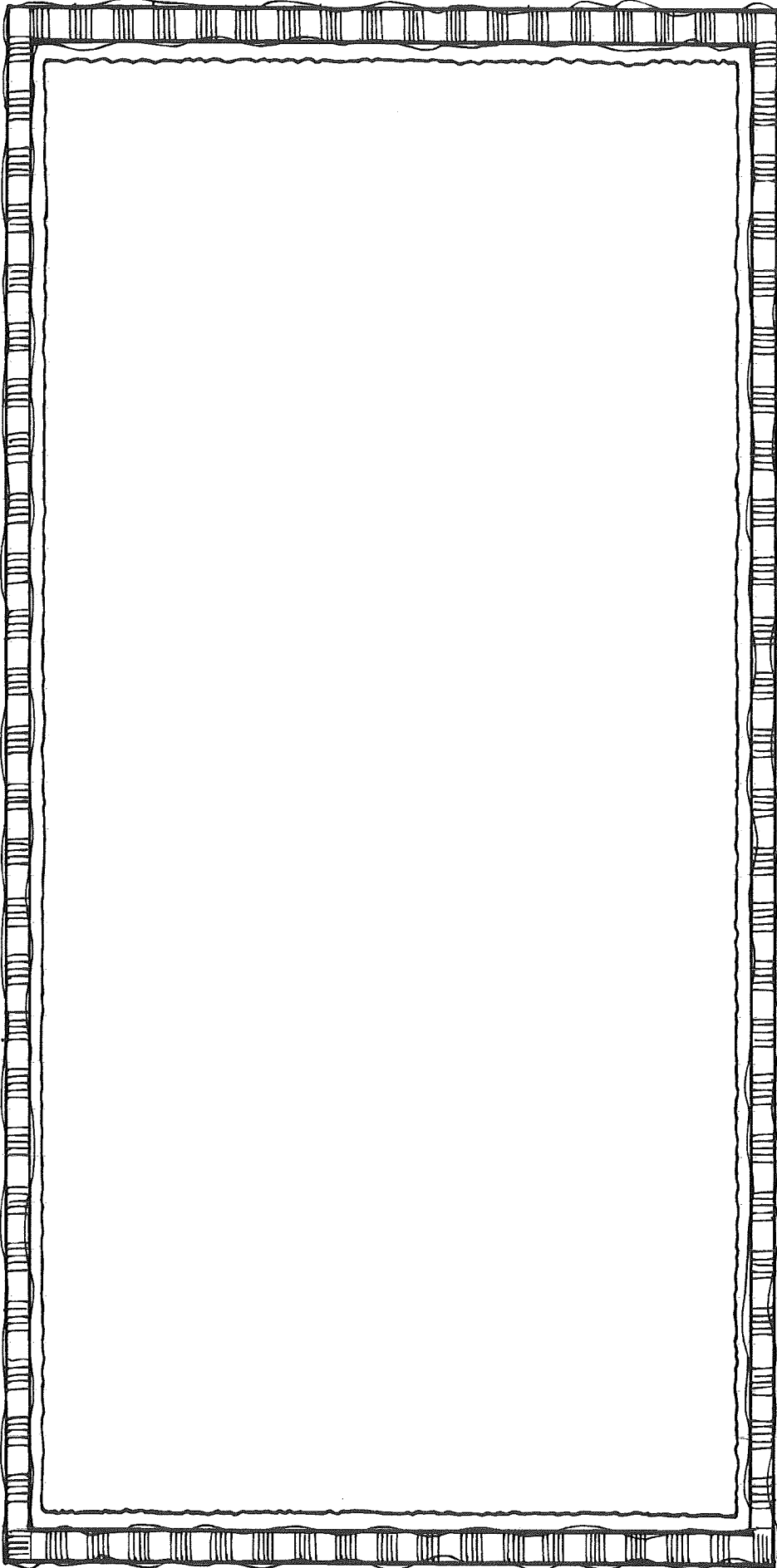

Handwriting practice lines consisting of four sets of horizontal lines. Each set includes a solid top line, a dashed middle line, and a solid bottom line.

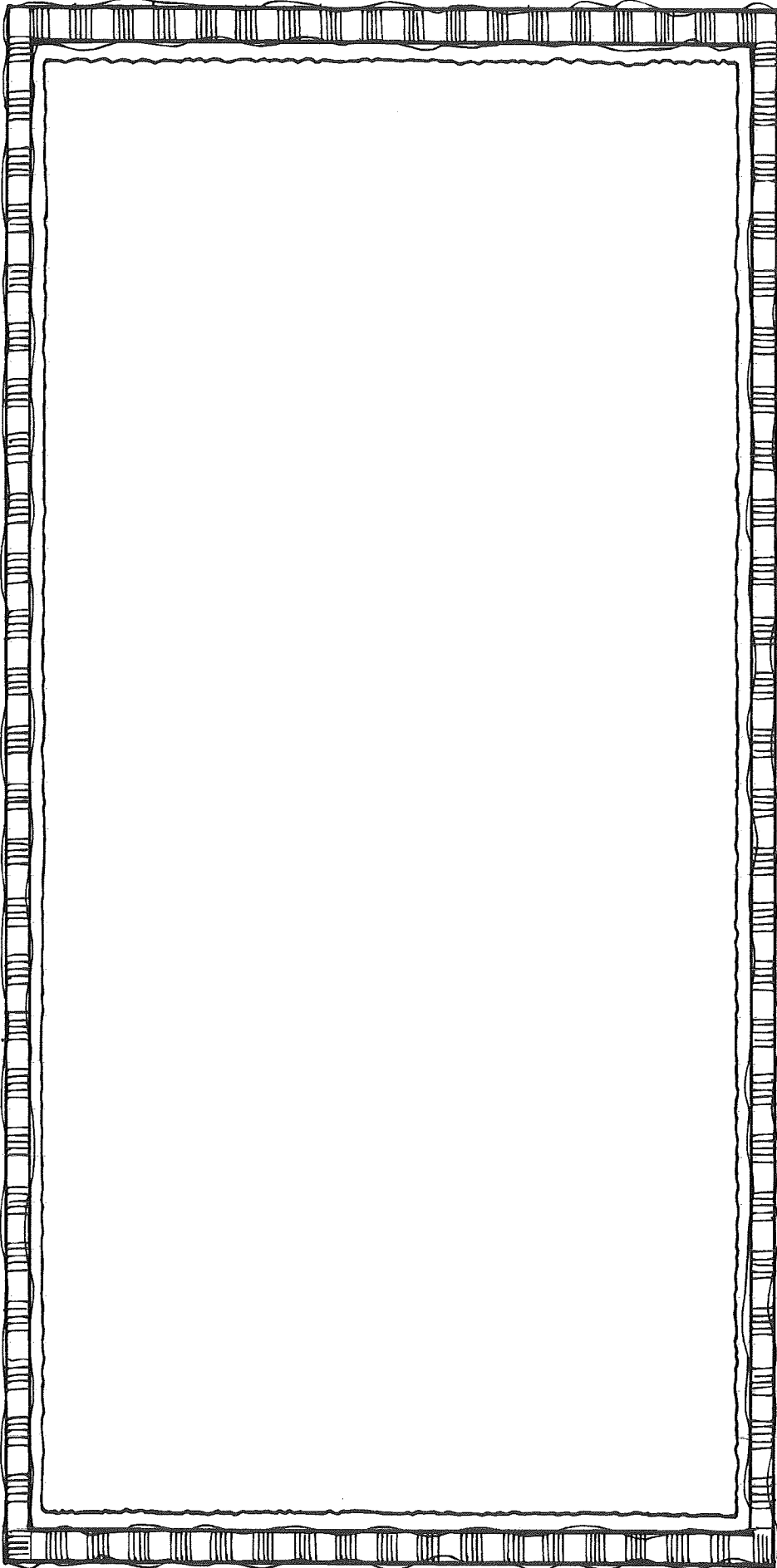

Handwriting practice lines consisting of four sets of horizontal lines. Each set includes a solid top line, a dashed middle line, and a solid bottom line, providing a guide for letter height and placement.

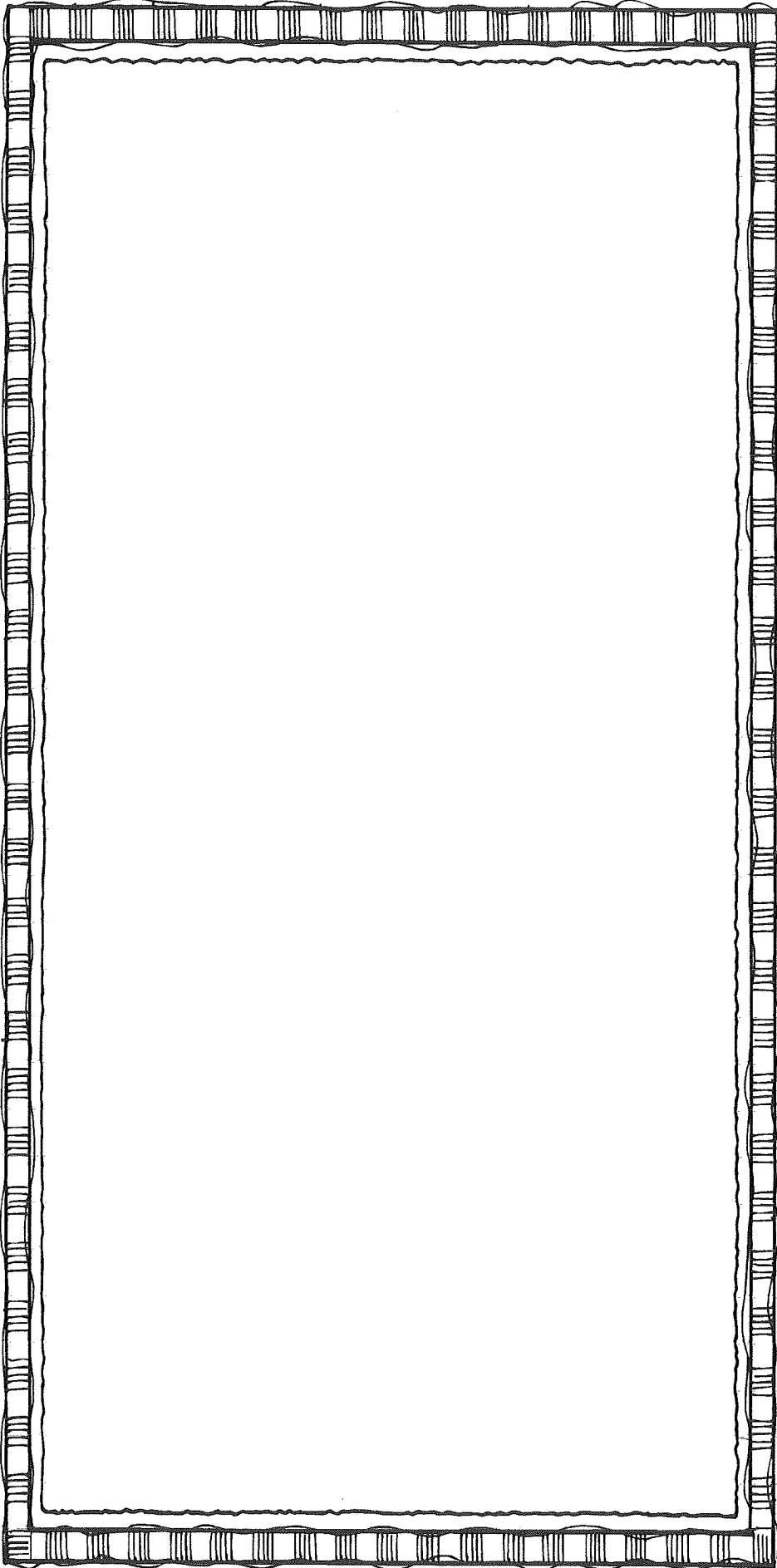

Four sets of horizontal writing lines. Each set consists of a solid top line, a dashed middle line, and a solid bottom line, providing a guide for letter height and placement.

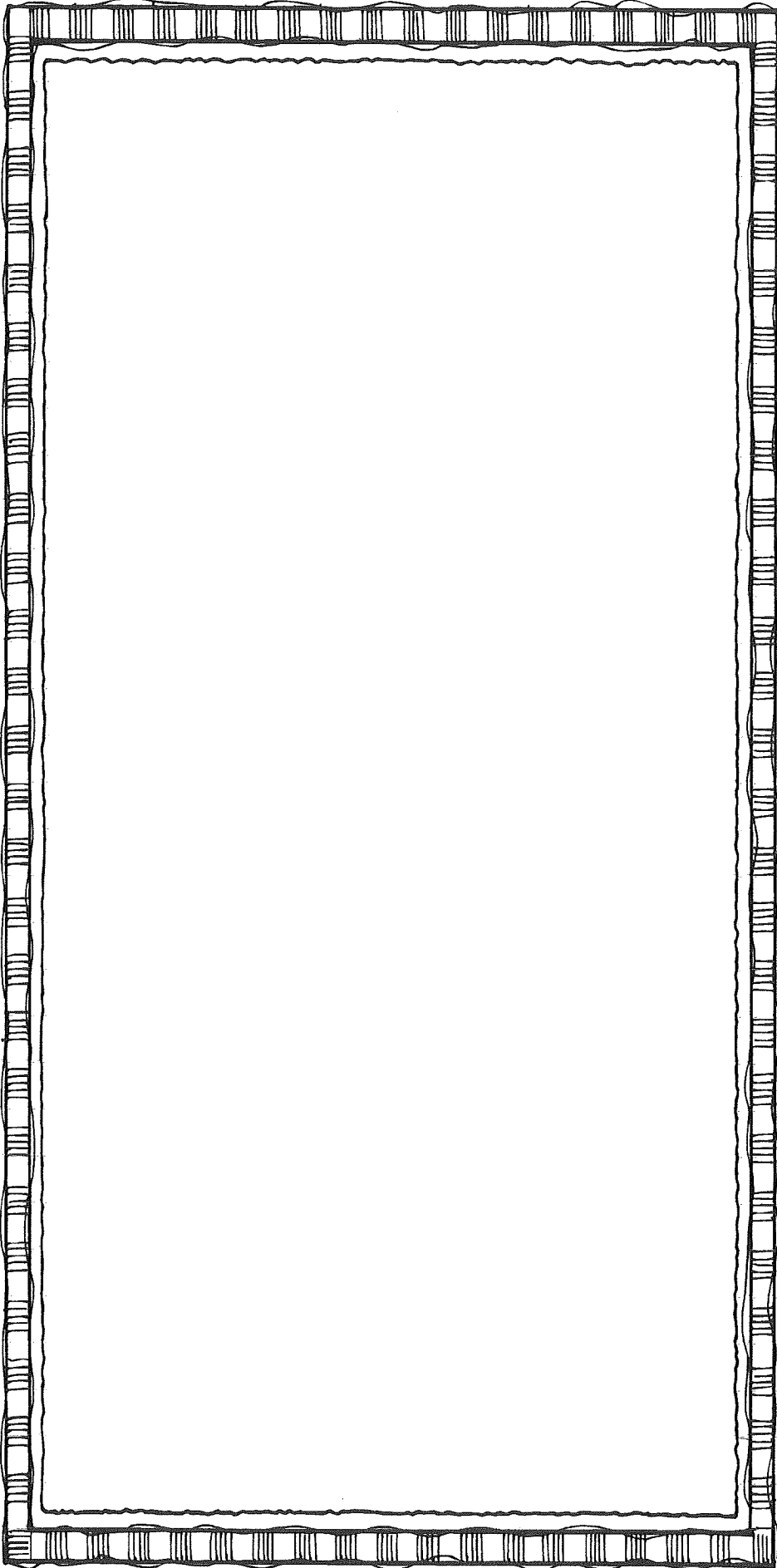

Four sets of horizontal writing lines. Each set consists of a solid top line, a dashed middle line, and a solid bottom line, providing a guide for letter height and placement.

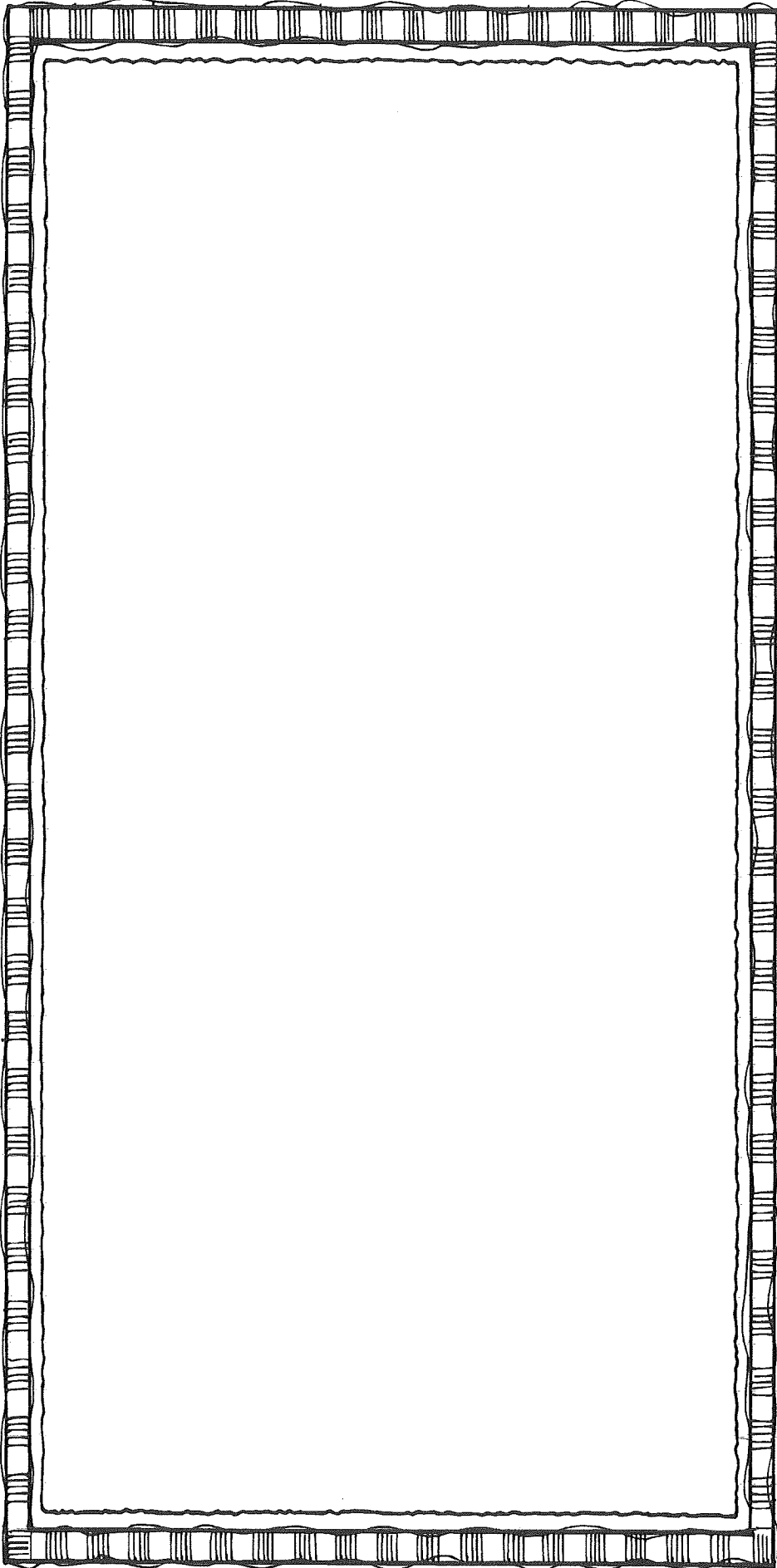

Handwriting practice lines consisting of four sets of horizontal lines. Each set includes a solid top line, a dashed middle line, and a solid bottom line.

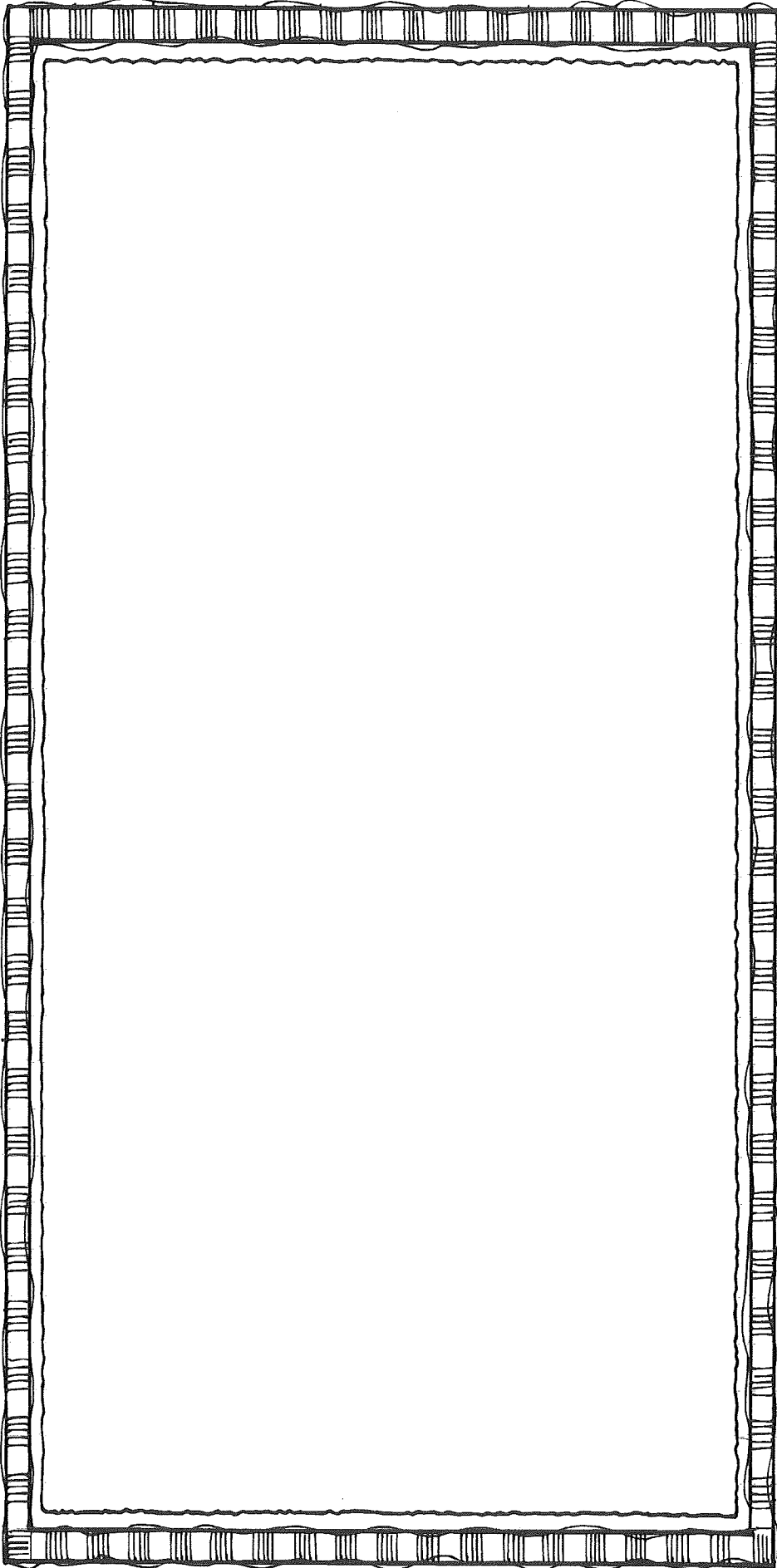

Four sets of horizontal writing lines. Each set consists of a solid top line, a dashed middle line, and a solid bottom line, providing a guide for letter height and placement.

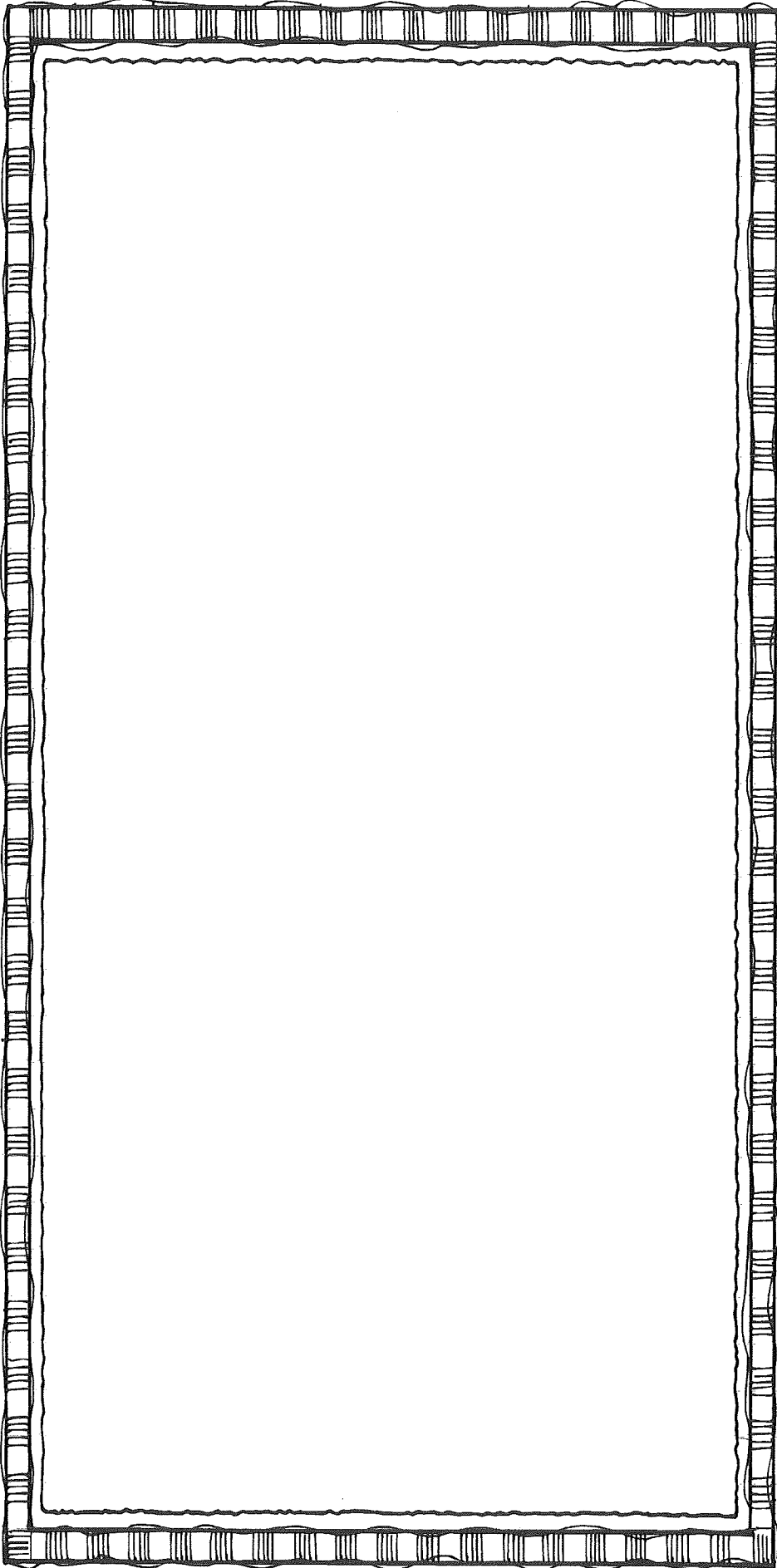

Handwriting practice lines consisting of four sets of horizontal lines. Each set includes a solid top line, a dashed middle line, and a solid bottom line.

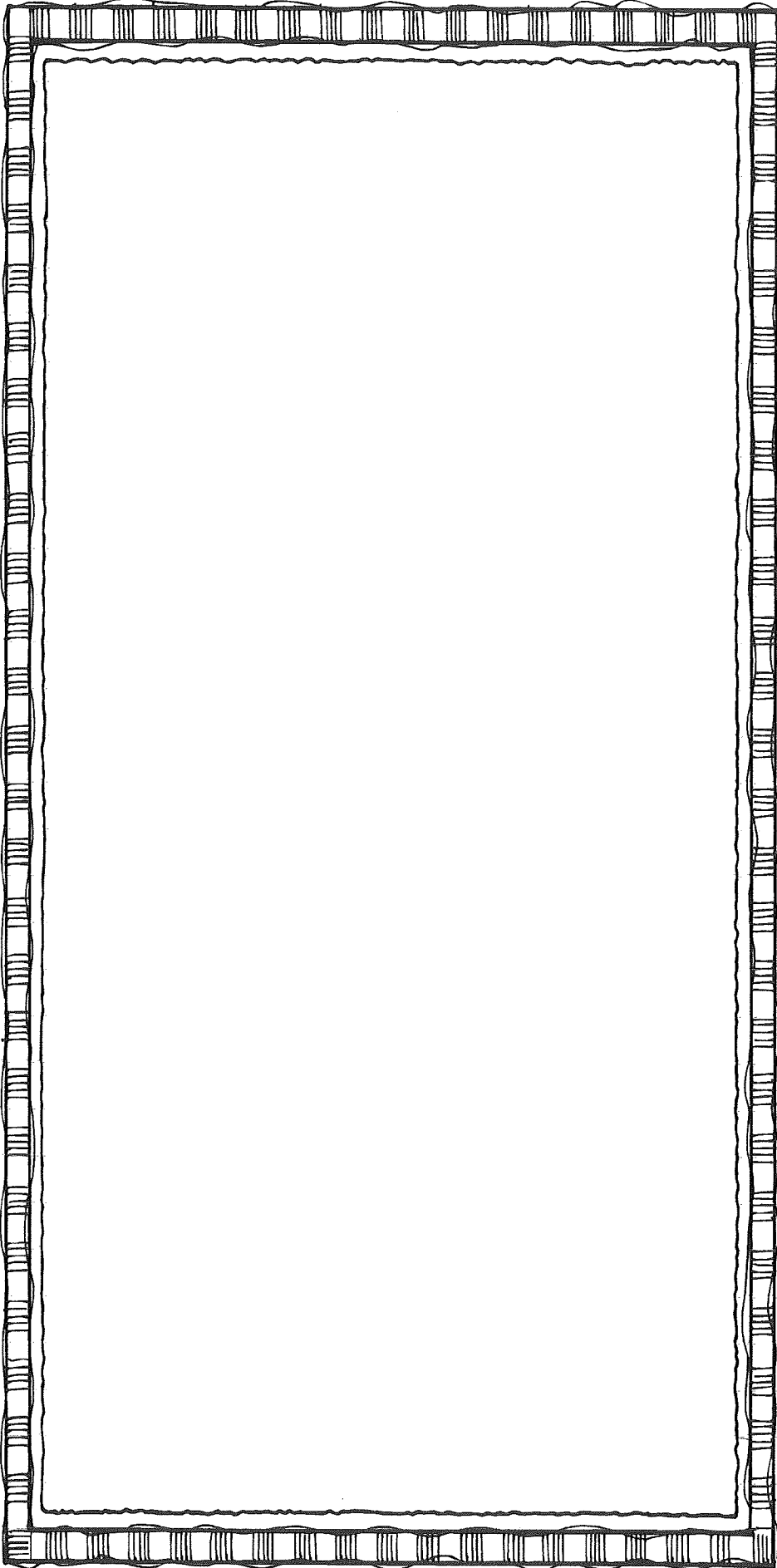

Handwriting practice lines consisting of four sets of horizontal lines. Each set includes a solid top line, a dashed middle line, and a solid bottom line, providing a guide for letter height and placement.

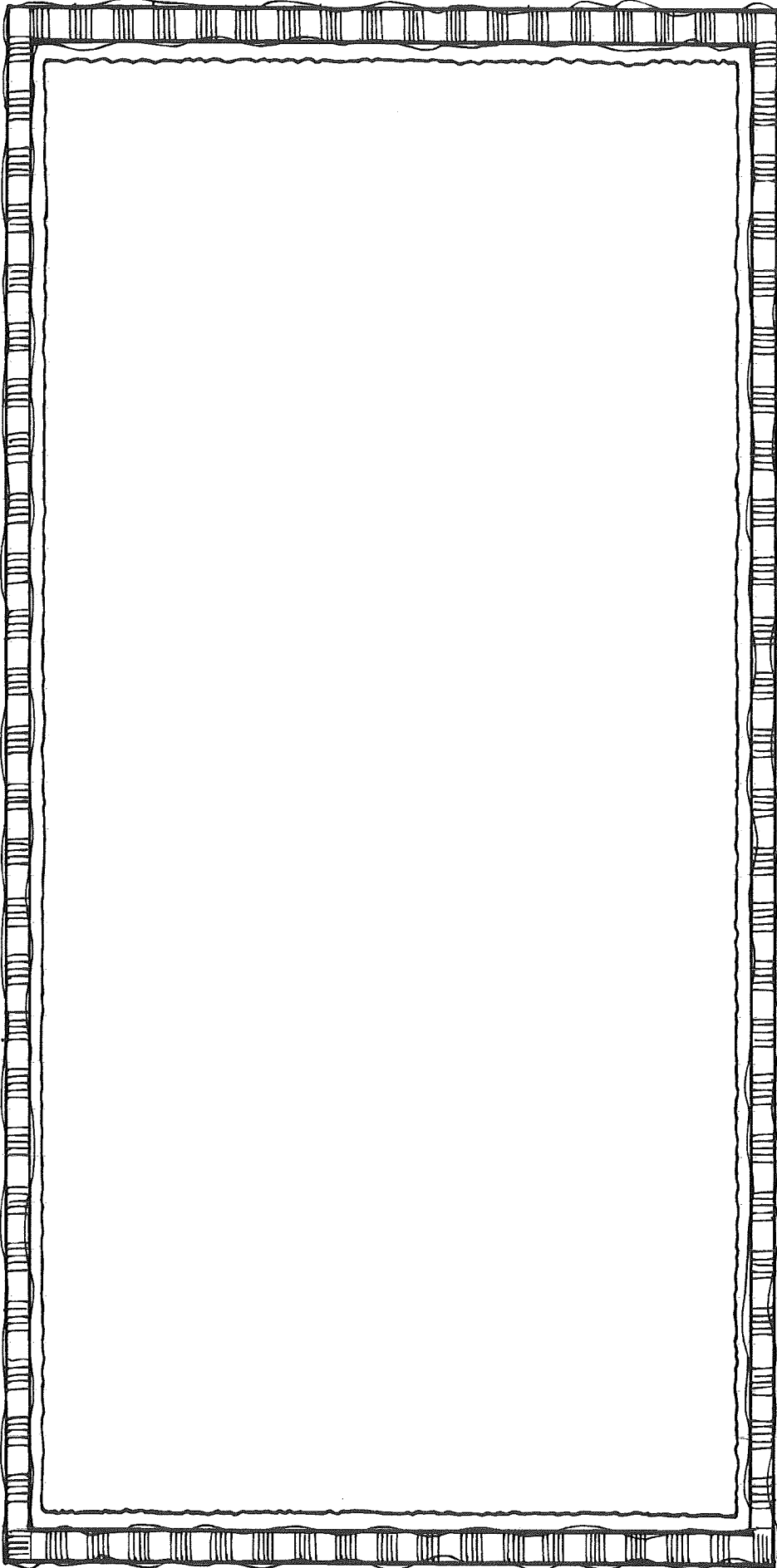

Four sets of horizontal writing lines. Each set consists of a solid top line, a dashed middle line, and a solid bottom line, providing a guide for letter height and placement.

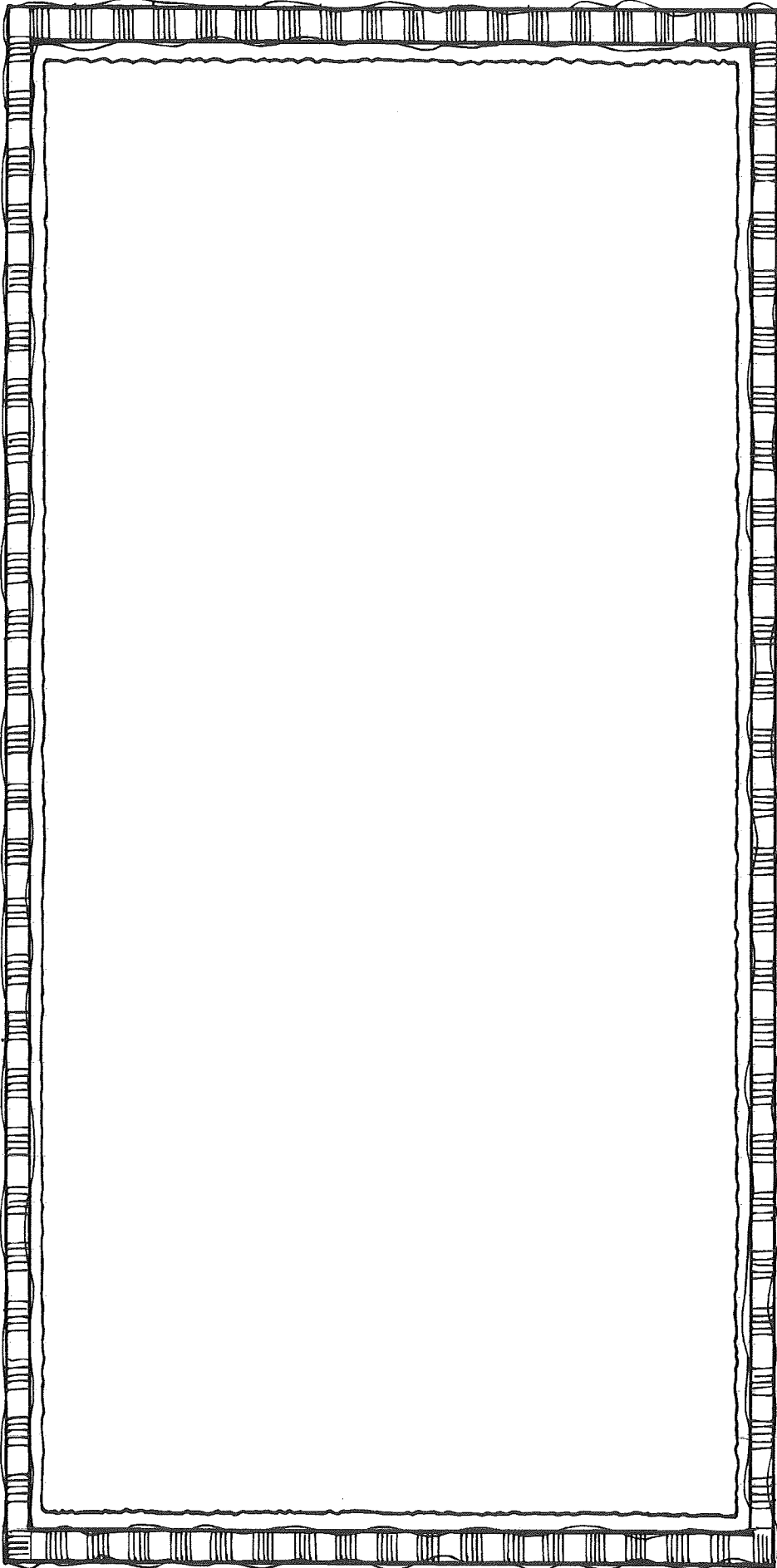

Handwriting practice lines consisting of four sets of horizontal lines. Each set includes a solid top line, a dashed middle line, and a solid bottom line.

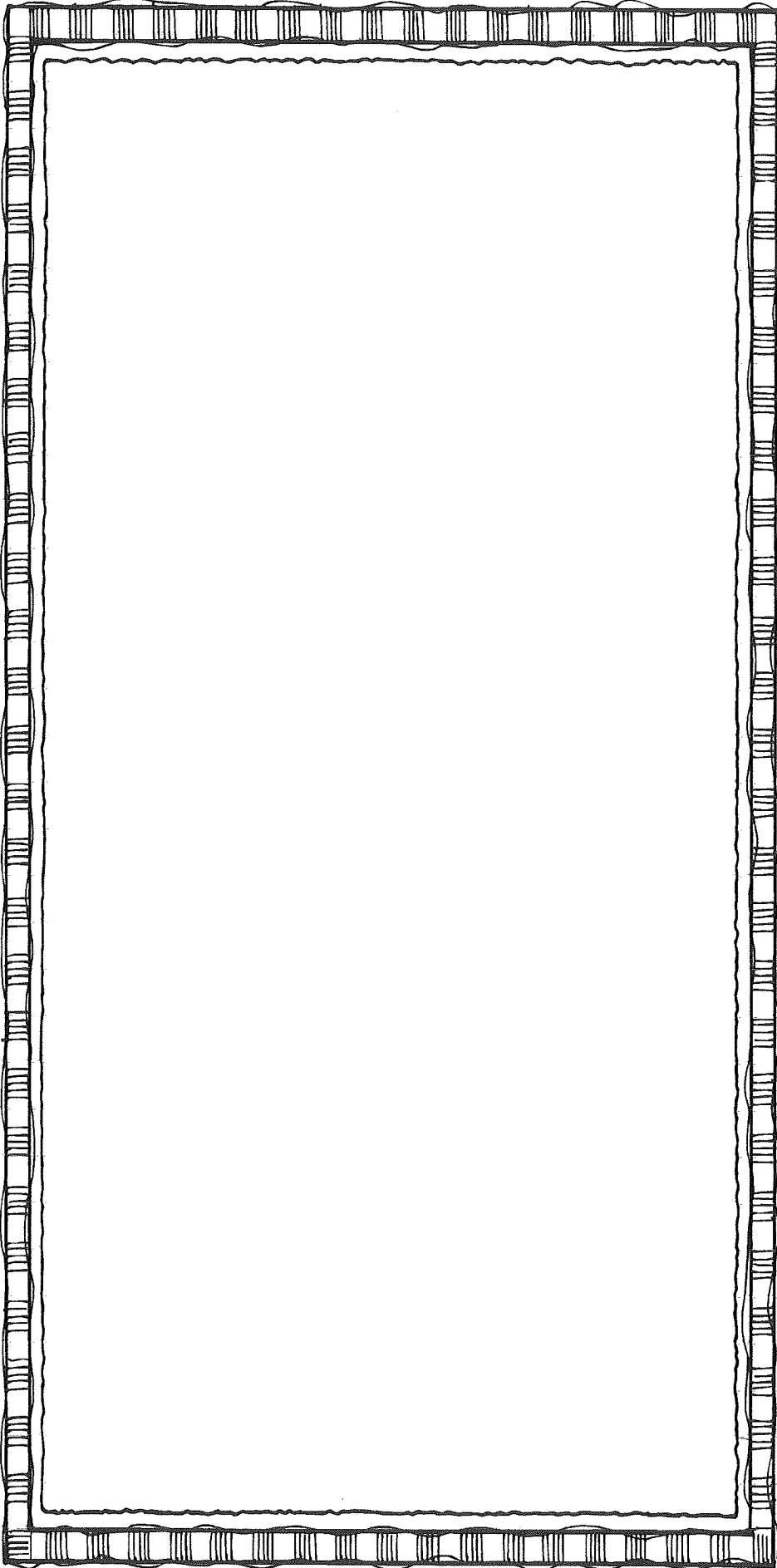

Handwriting practice lines consisting of four sets of horizontal lines. Each set includes a solid top line, a dashed middle line, and a solid bottom line.

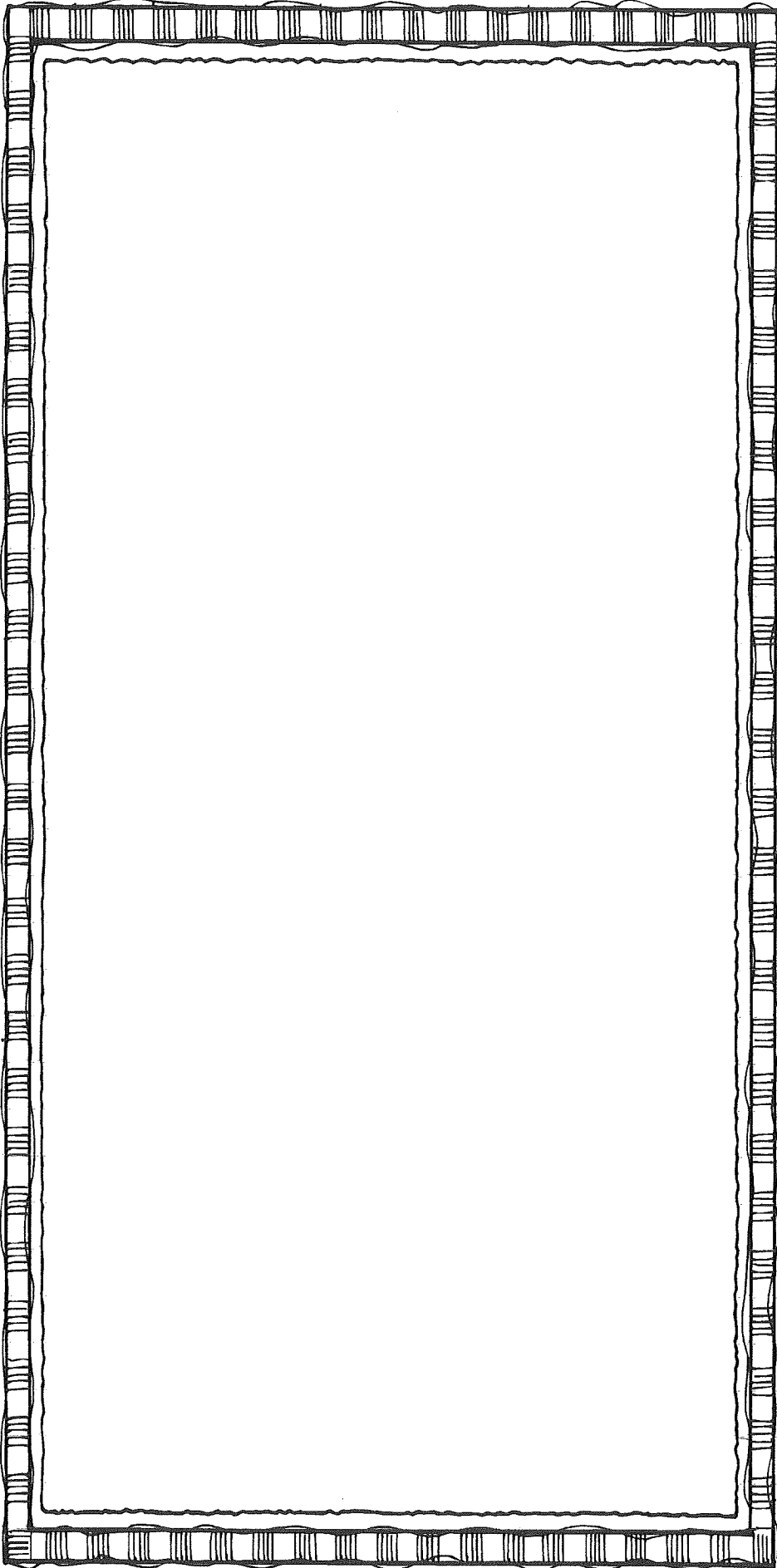

Handwriting practice lines consisting of four sets of horizontal lines. Each set includes a solid top line, a dashed middle line, and a solid bottom line, providing a guide for letter height and placement.

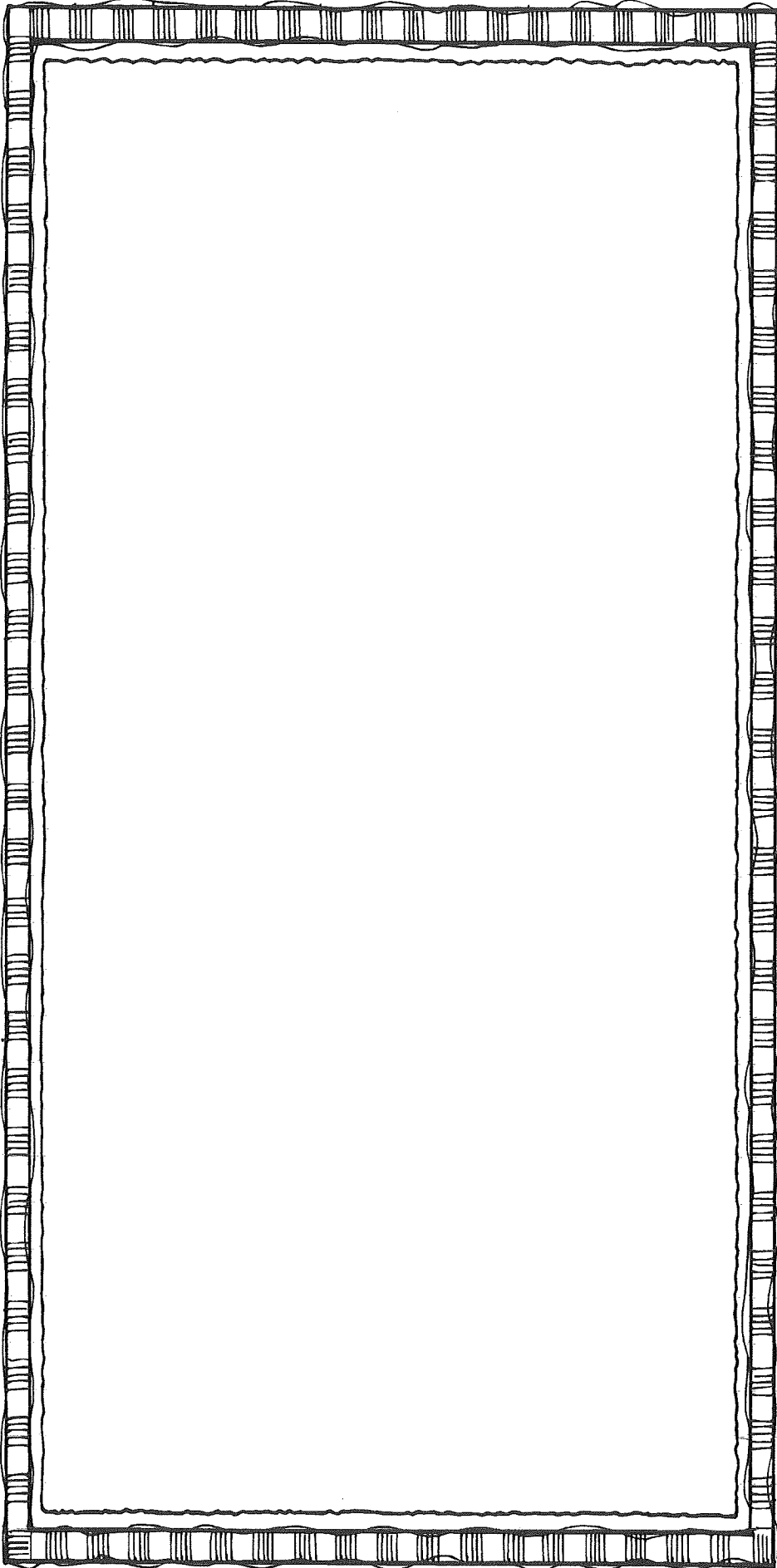

Handwriting practice lines consisting of four sets of horizontal lines. Each set includes a solid top line, a dashed middle line, and a solid bottom line.

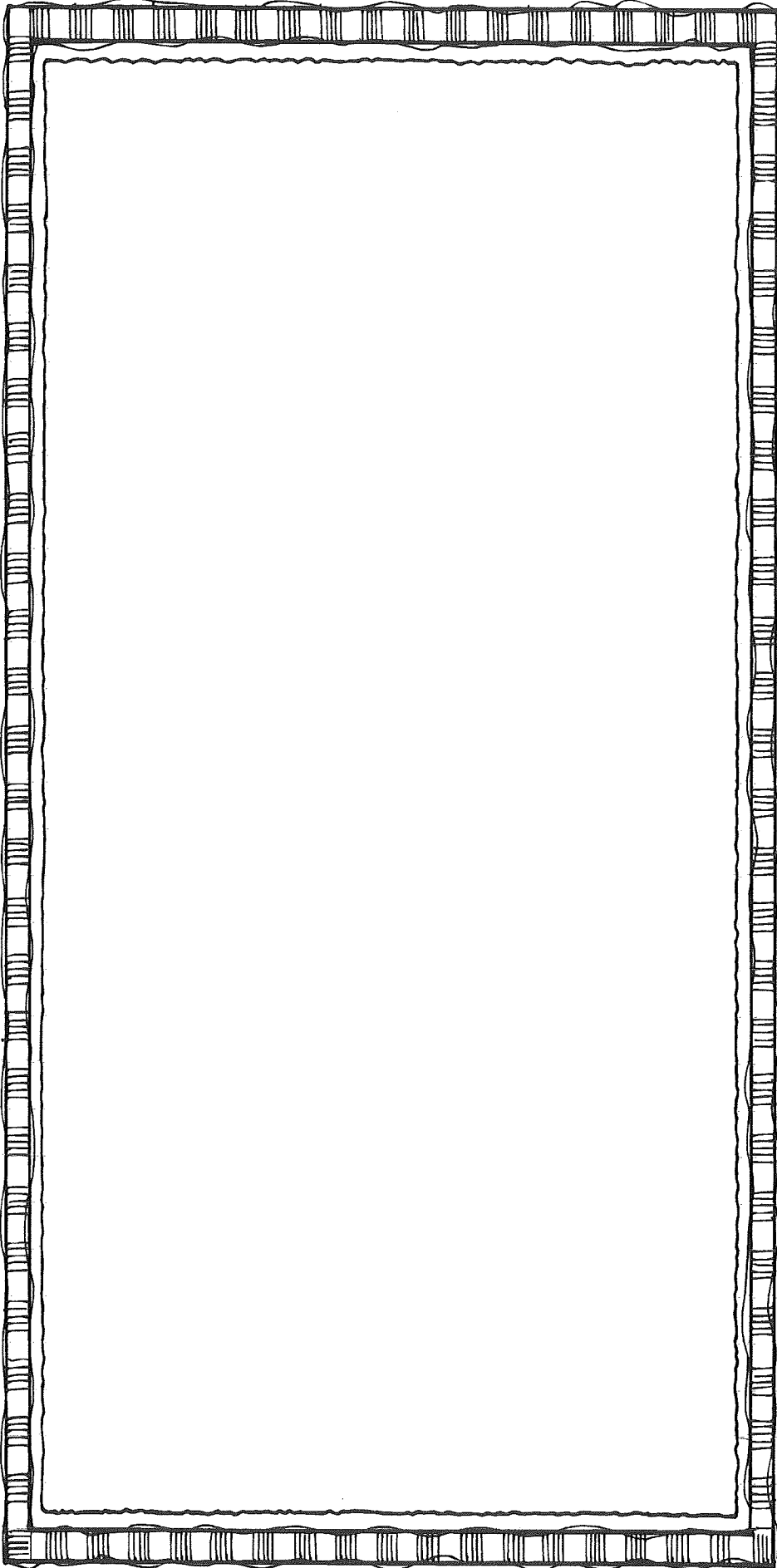

Handwriting practice lines consisting of four sets of horizontal lines. Each set includes a solid top line, a dashed middle line, and a solid bottom line.

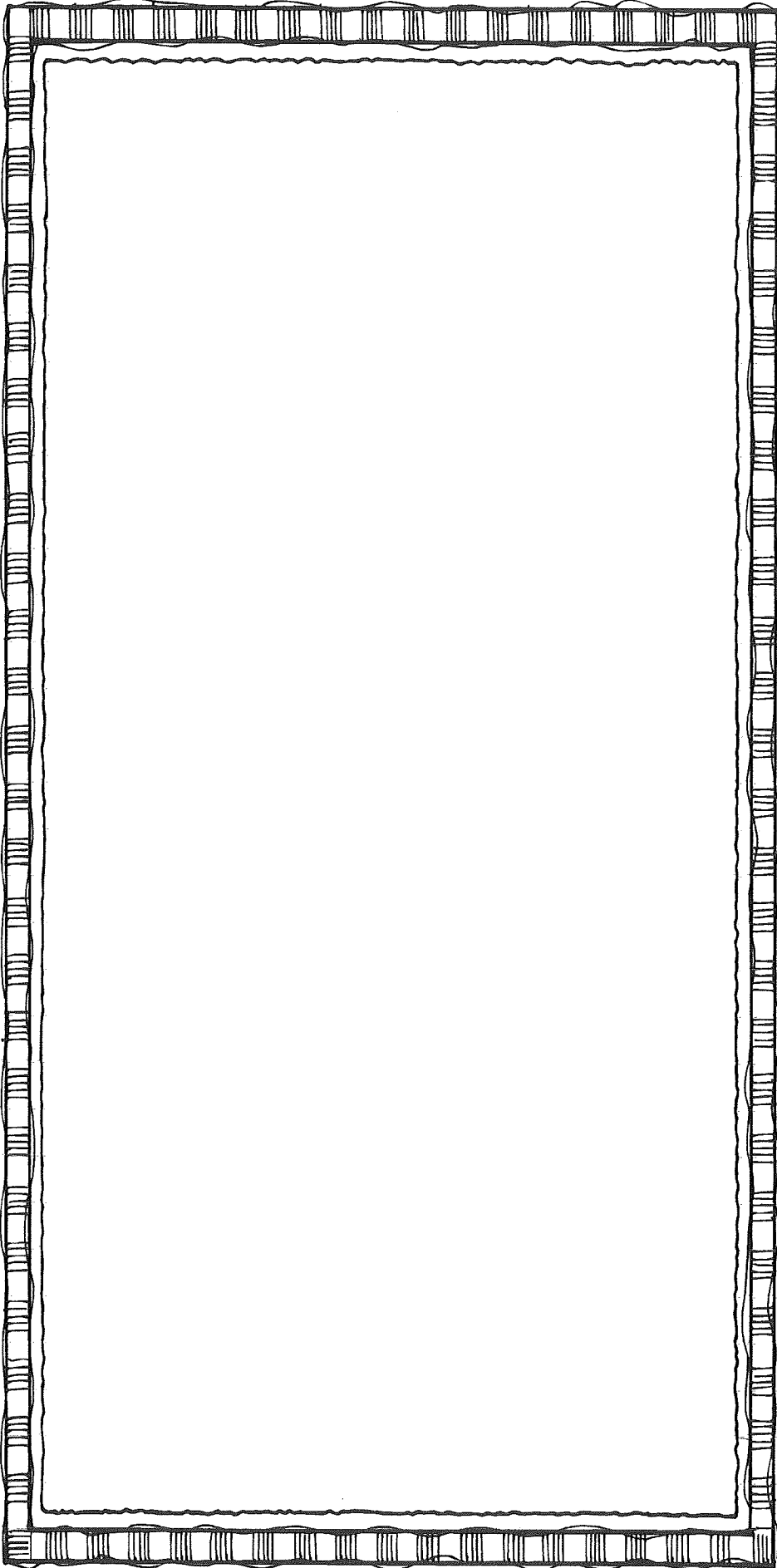

Four sets of horizontal writing lines. Each set consists of a solid top line, a dashed middle line, and a solid bottom line, providing a guide for letter height and placement.

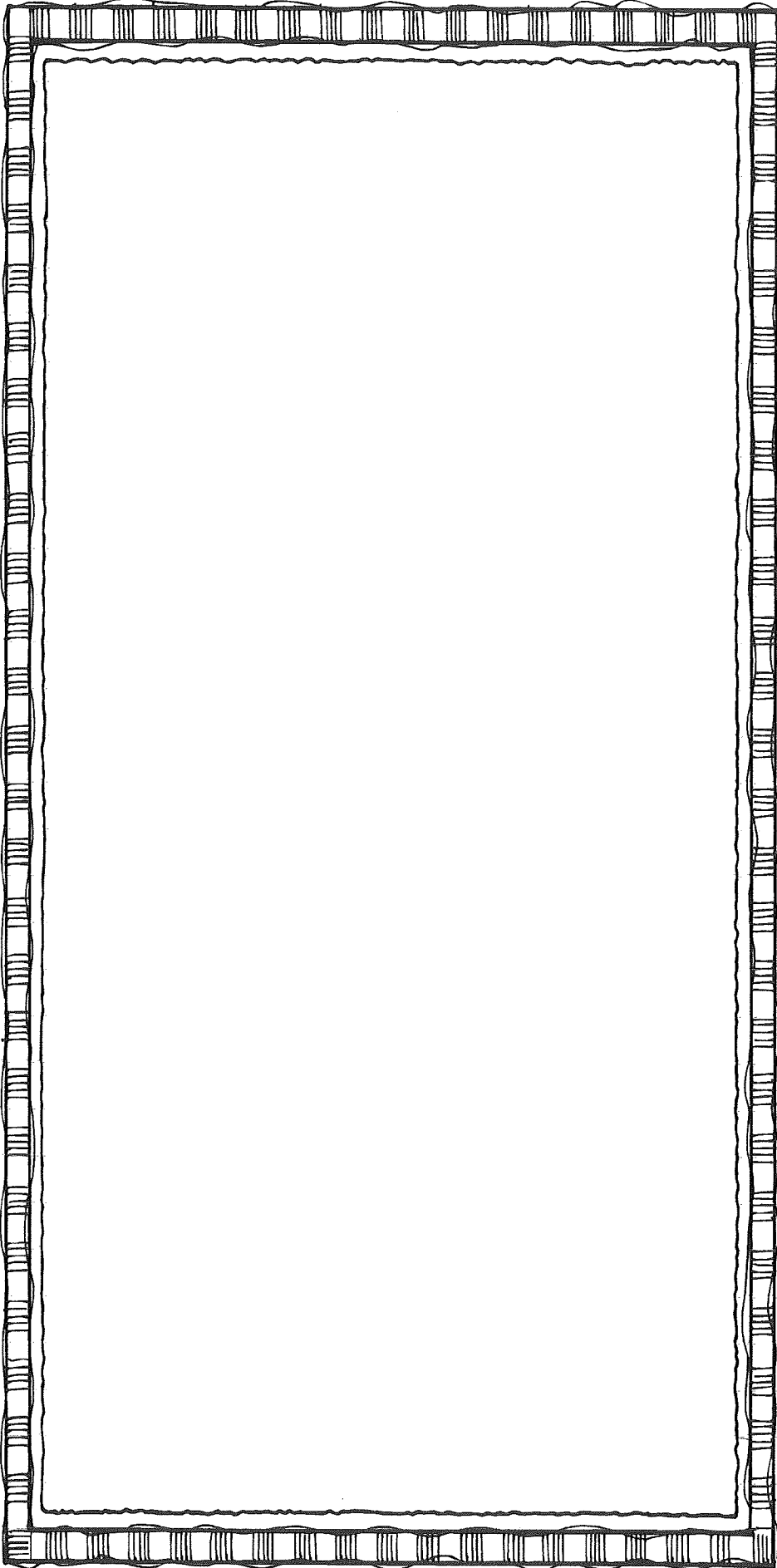

Handwriting practice lines consisting of four sets of horizontal lines. Each set includes a solid top line, a dashed middle line, and a solid bottom line, providing a guide for letter height and placement.

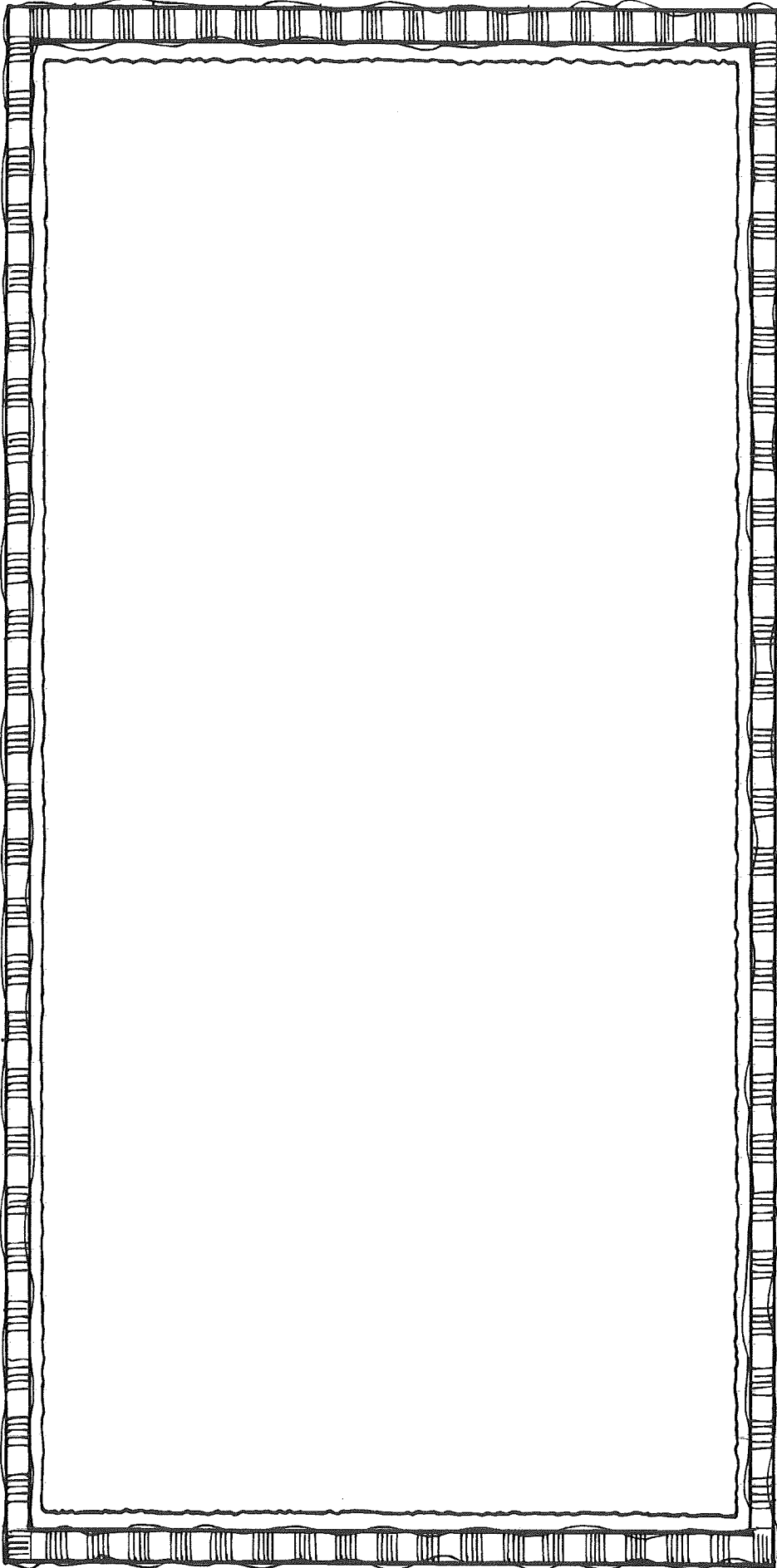

Handwriting practice lines consisting of four sets of horizontal lines. Each set includes a solid top line, a dashed middle line, and a solid bottom line.

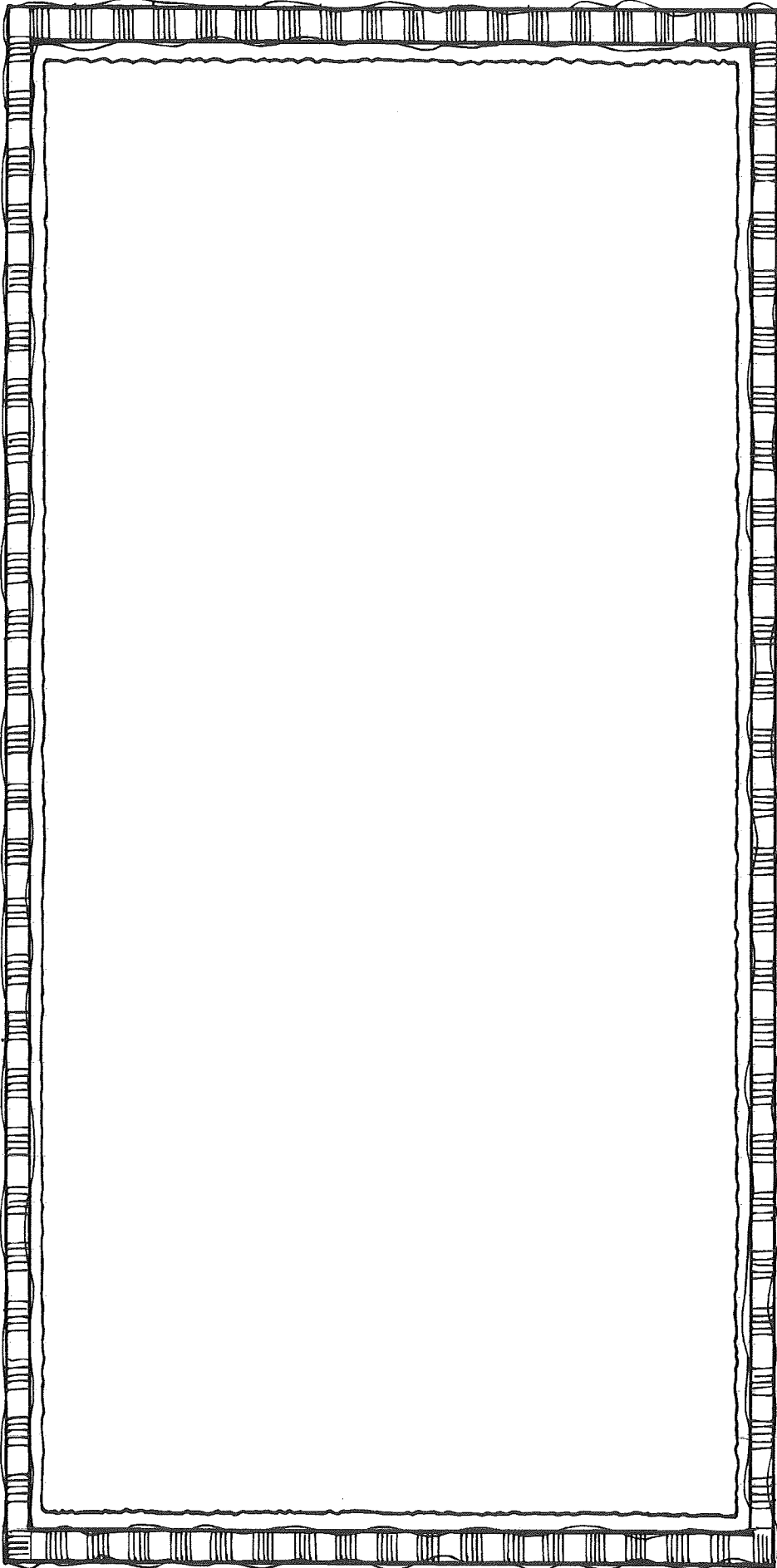

Handwriting practice lines consisting of four sets of horizontal lines. Each set includes a solid top line, a dashed middle line, and a solid bottom line, providing a guide for letter height and placement.

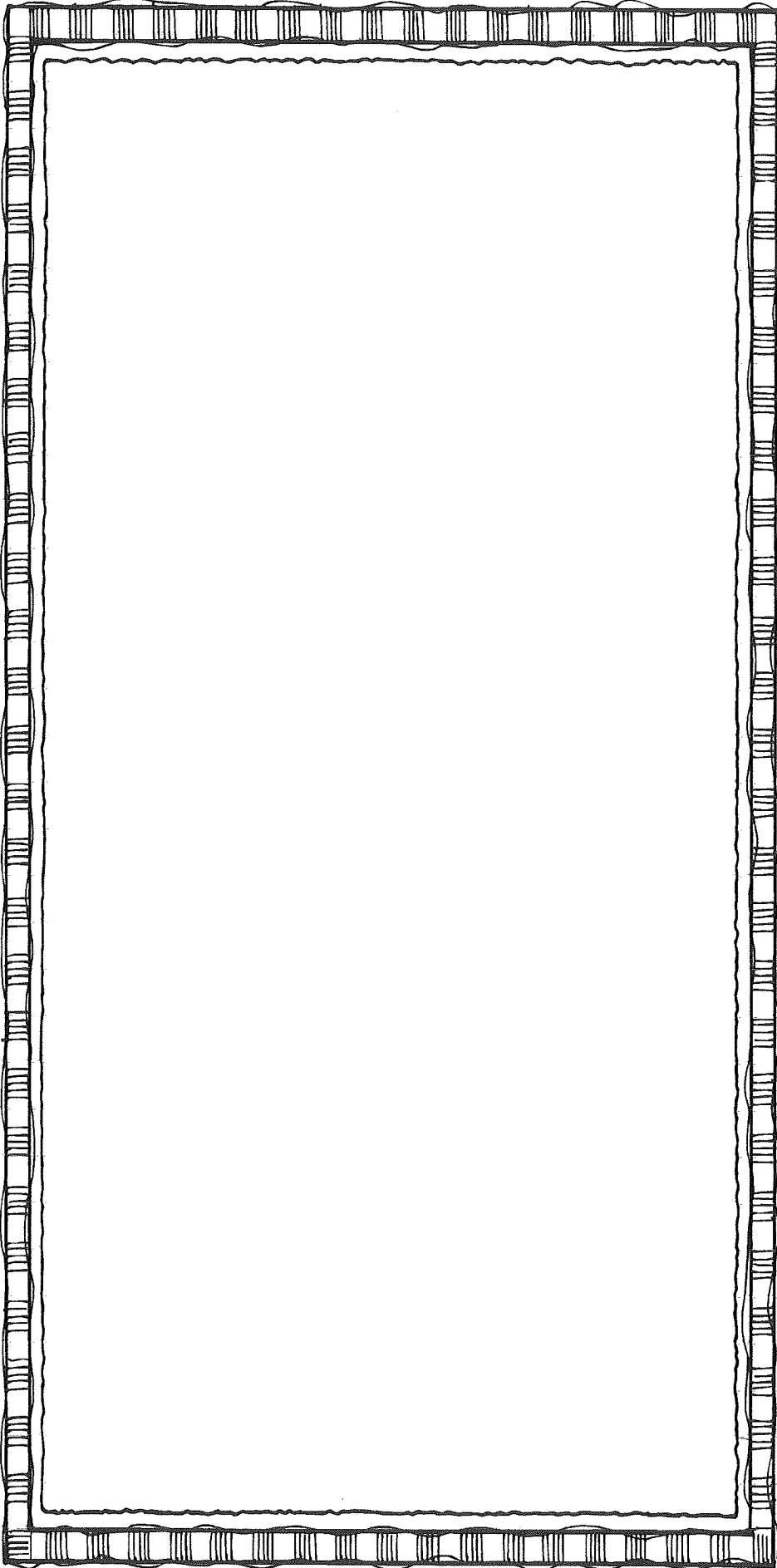

Handwriting practice lines consisting of four sets of horizontal lines. Each set includes a solid top line, a dashed middle line, and a solid bottom line, providing a guide for letter height and placement.

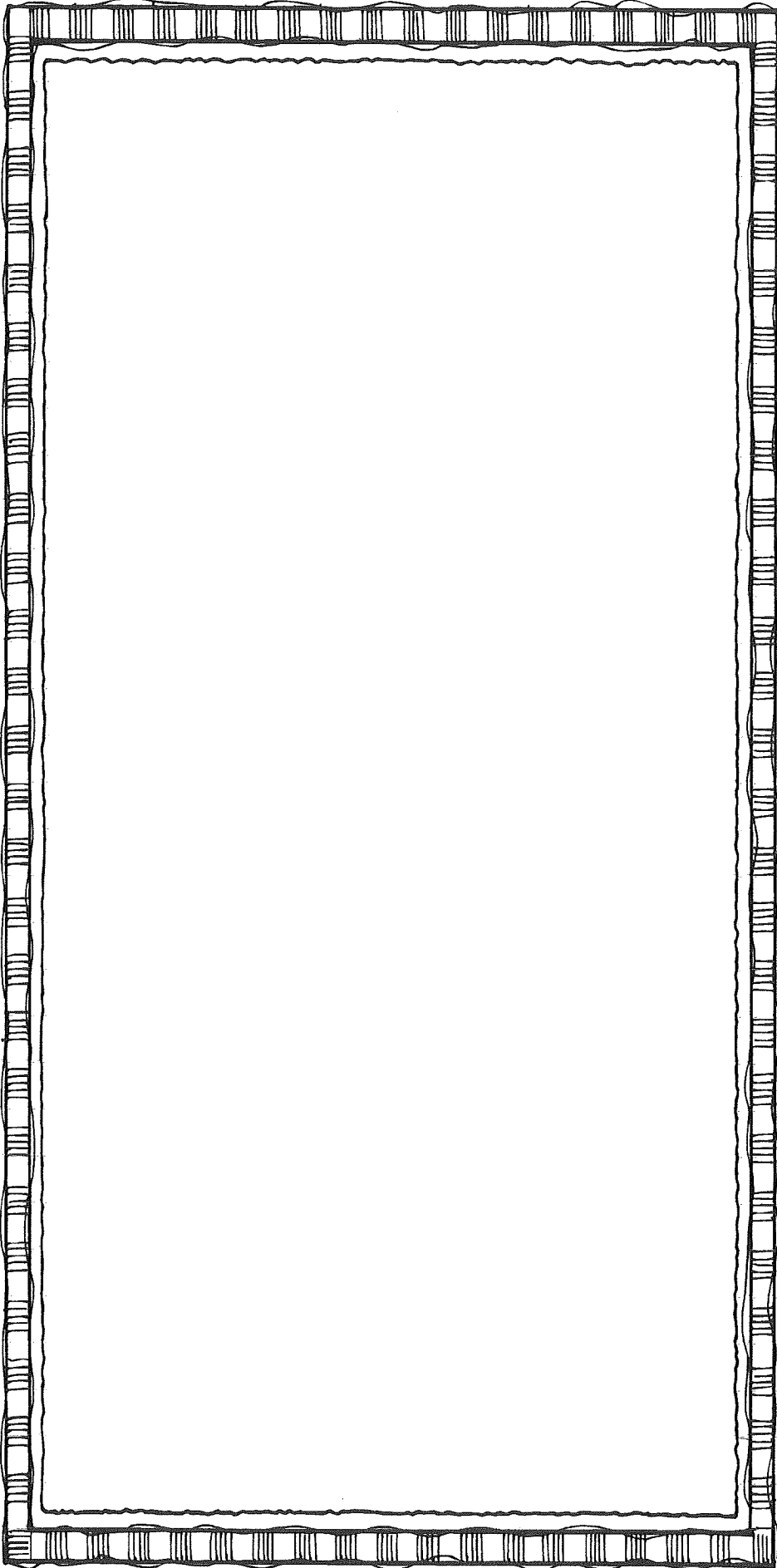

Handwriting practice lines consisting of four sets of horizontal lines. Each set includes a solid top line, a dashed middle line, and a solid bottom line, providing a guide for letter height and placement.

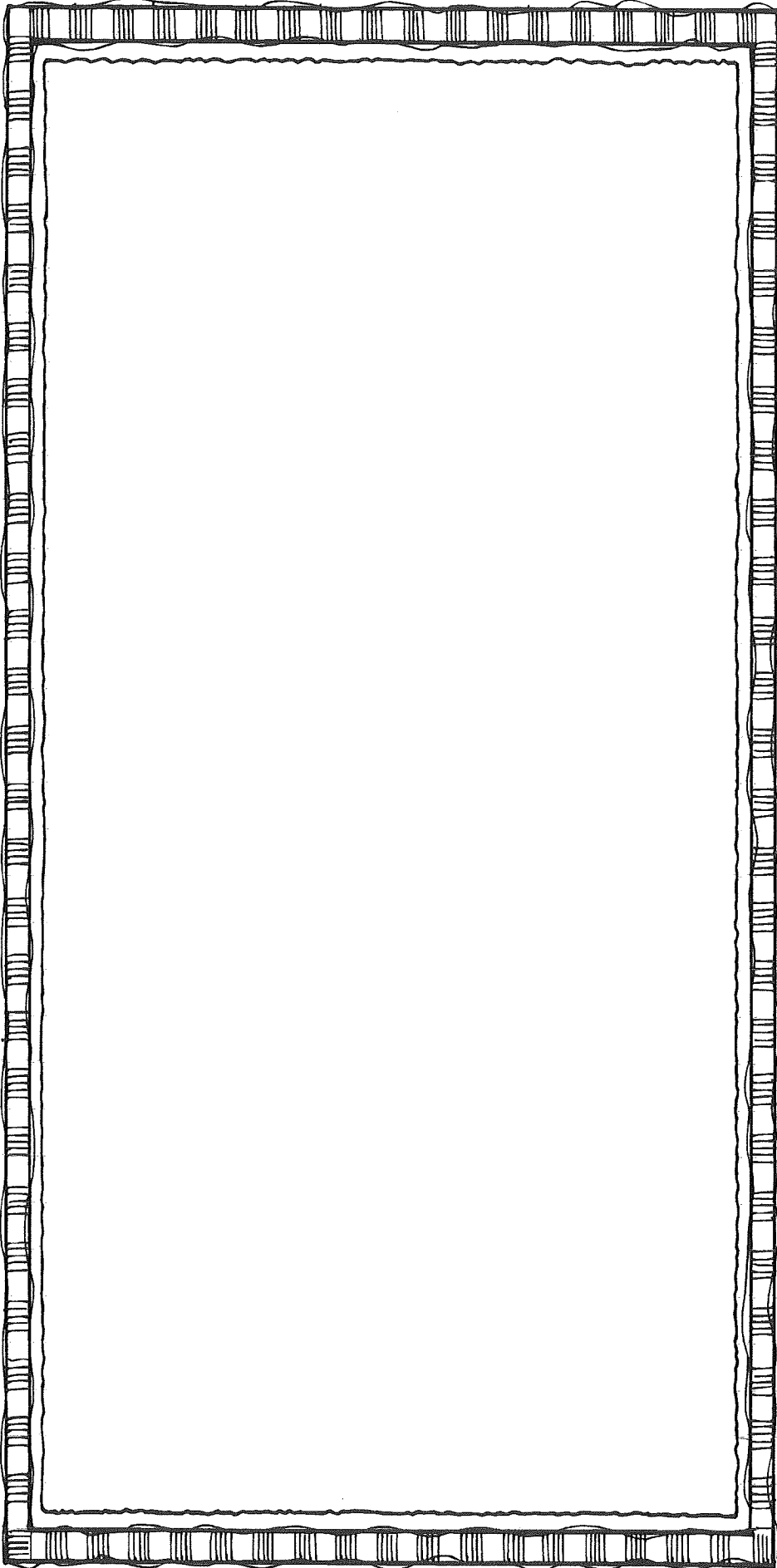

Handwriting practice lines consisting of four sets of horizontal lines. Each set includes a solid top line, a dashed middle line, and a solid bottom line.

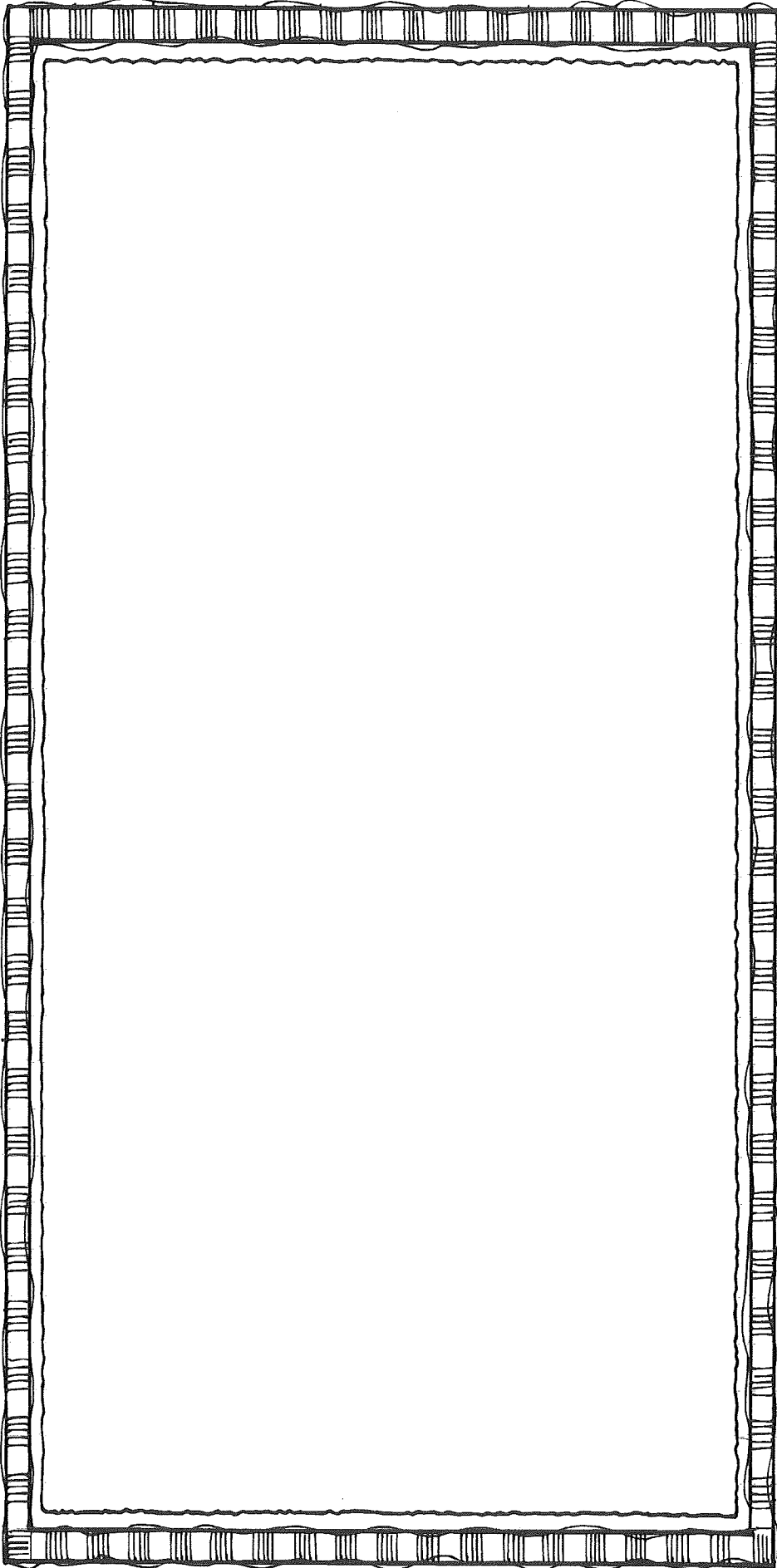

Handwriting practice lines consisting of four sets of horizontal lines. Each set includes a solid top line, a dashed middle line, and a solid bottom line, providing a guide for letter height and placement.

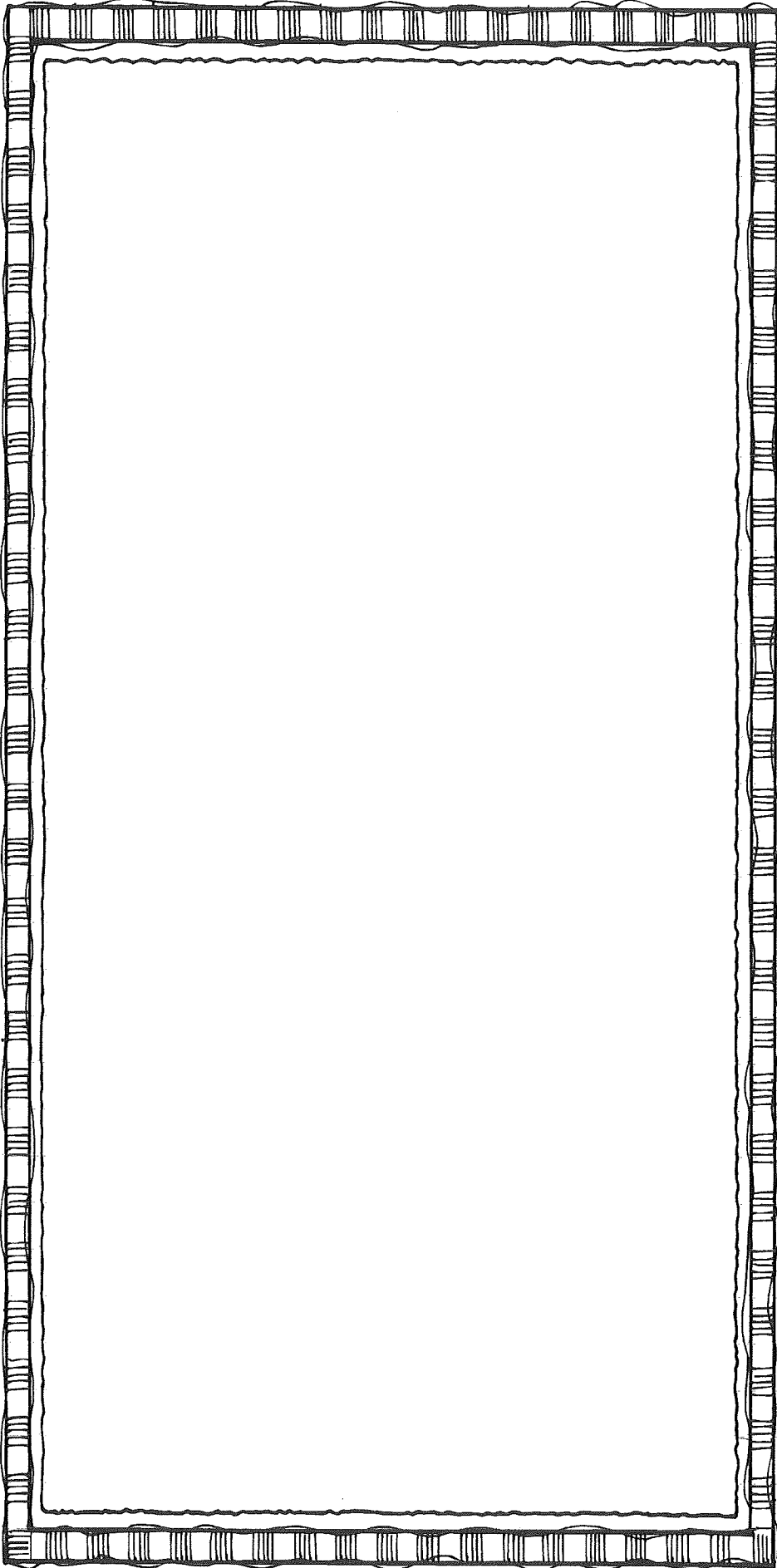

Handwriting practice lines consisting of four sets of horizontal lines. Each set includes a solid top line, a dashed middle line, and a solid bottom line, providing a guide for letter height and placement.

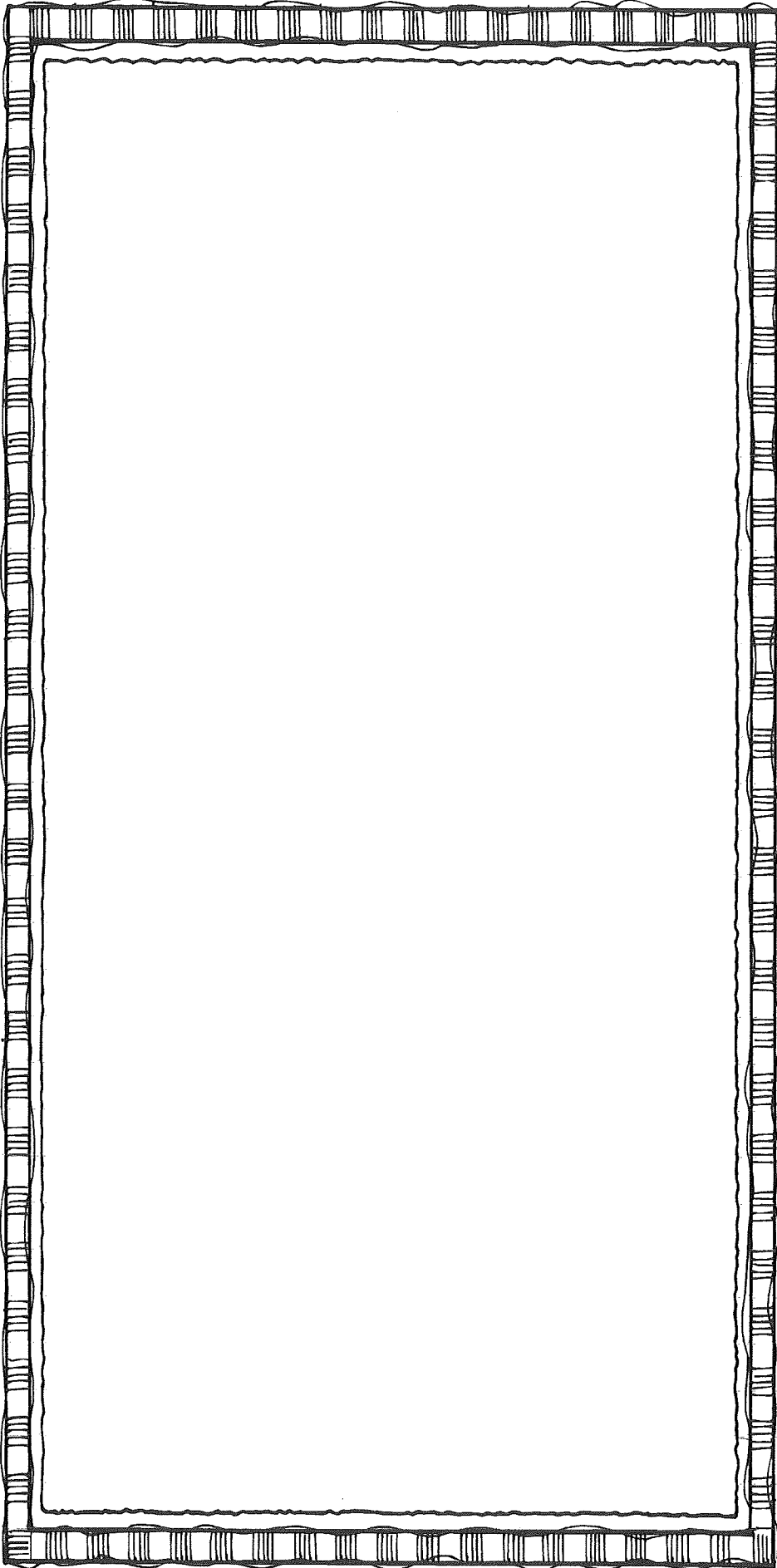

Handwriting practice lines consisting of four sets of horizontal lines. Each set includes a solid top line, a dashed middle line, and a solid bottom line, providing a guide for letter height and placement.

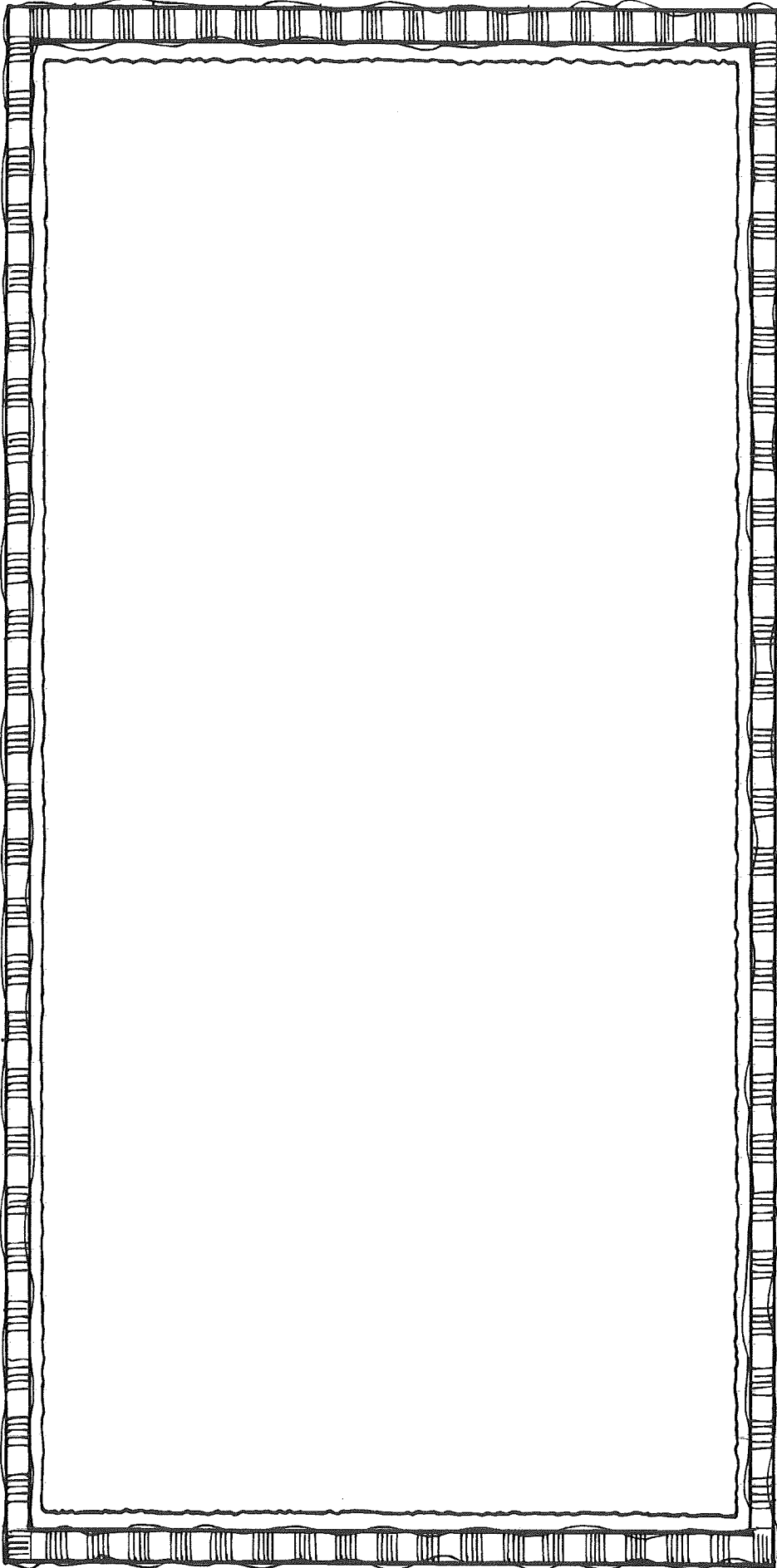

Handwriting practice lines consisting of four sets of horizontal lines. Each set includes a solid top line, a dashed middle line, and a solid bottom line.

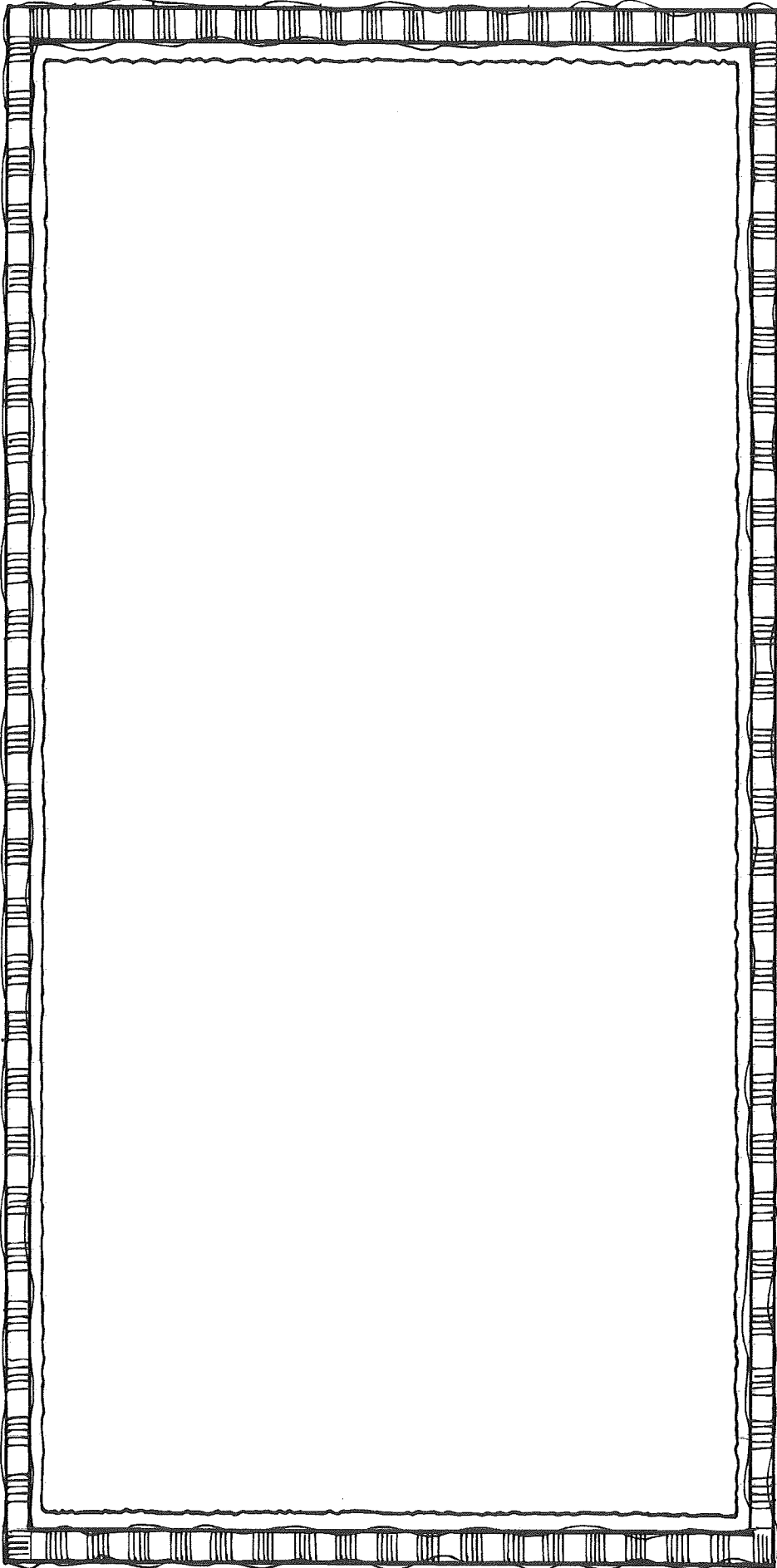

Handwriting practice lines consisting of four sets of horizontal lines. Each set includes a solid top line, a dashed middle line, and a solid bottom line, providing a guide for letter height and placement.

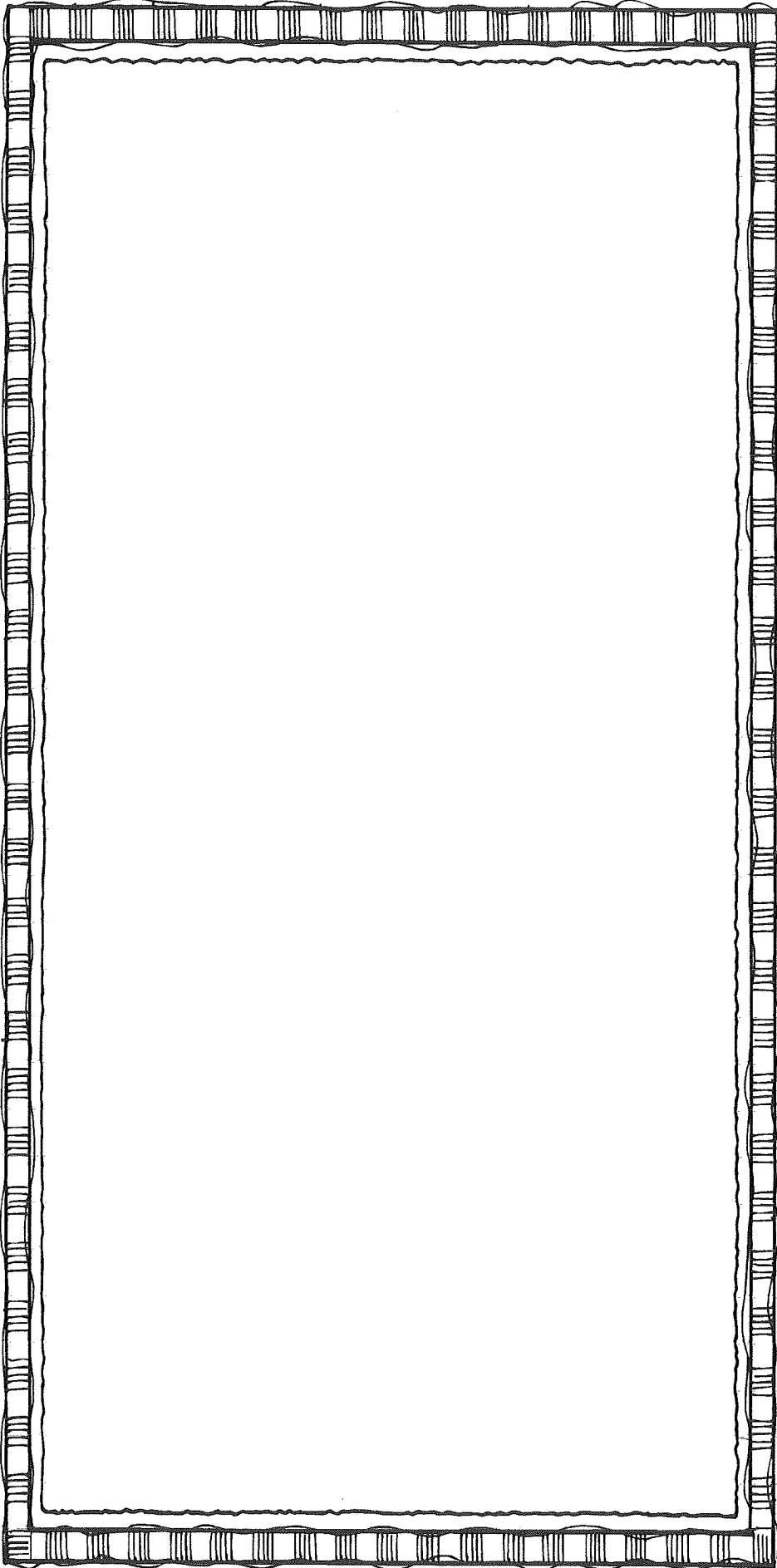

Handwriting practice lines consisting of four sets of horizontal lines. Each set includes a solid top line, a dashed middle line, and a solid bottom line, providing a guide for letter height and placement.

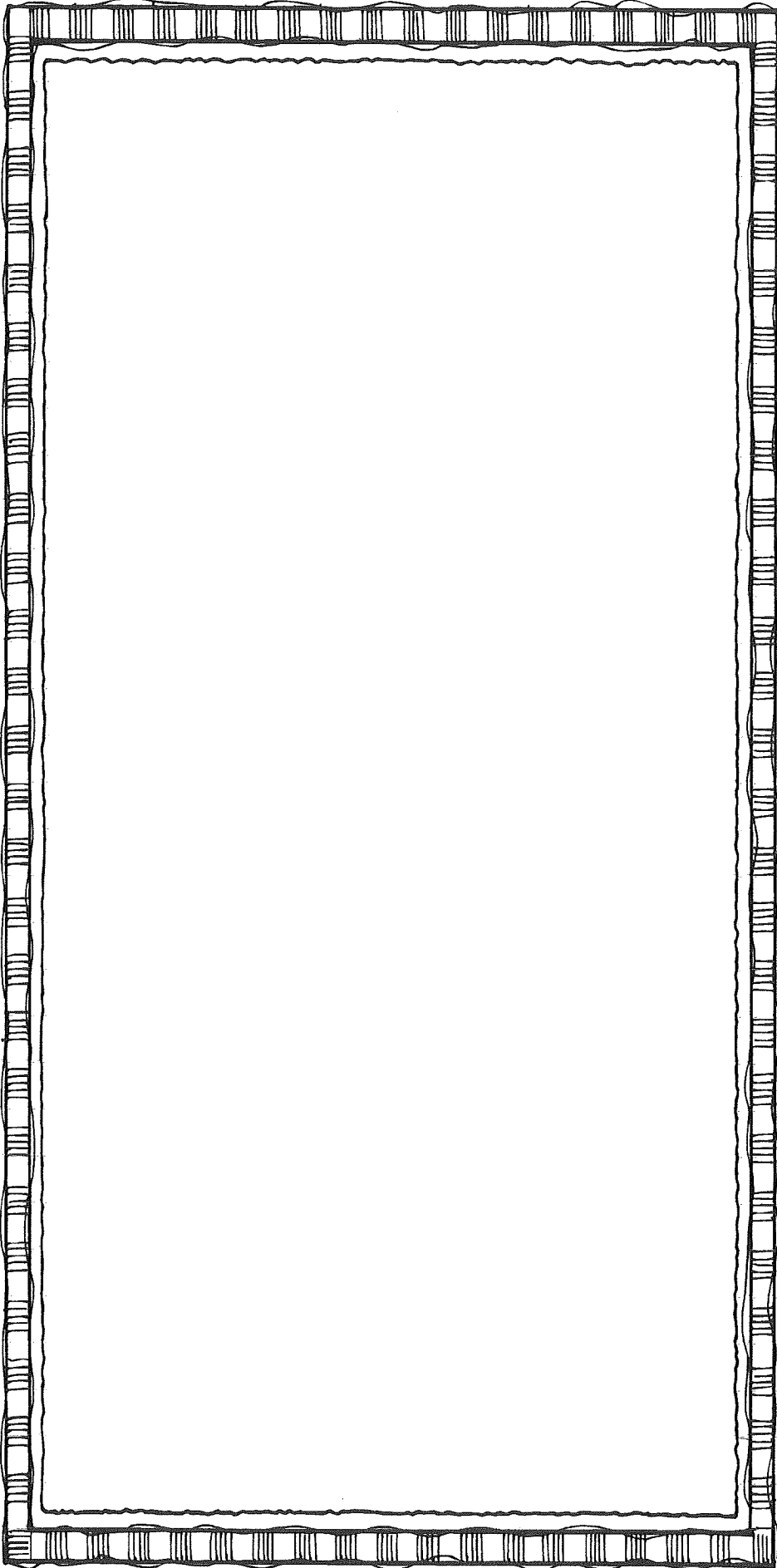

Handwriting practice lines consisting of four sets of horizontal lines. Each set includes a solid top line, a dashed middle line, and a solid bottom line, providing a guide for letter height and placement.

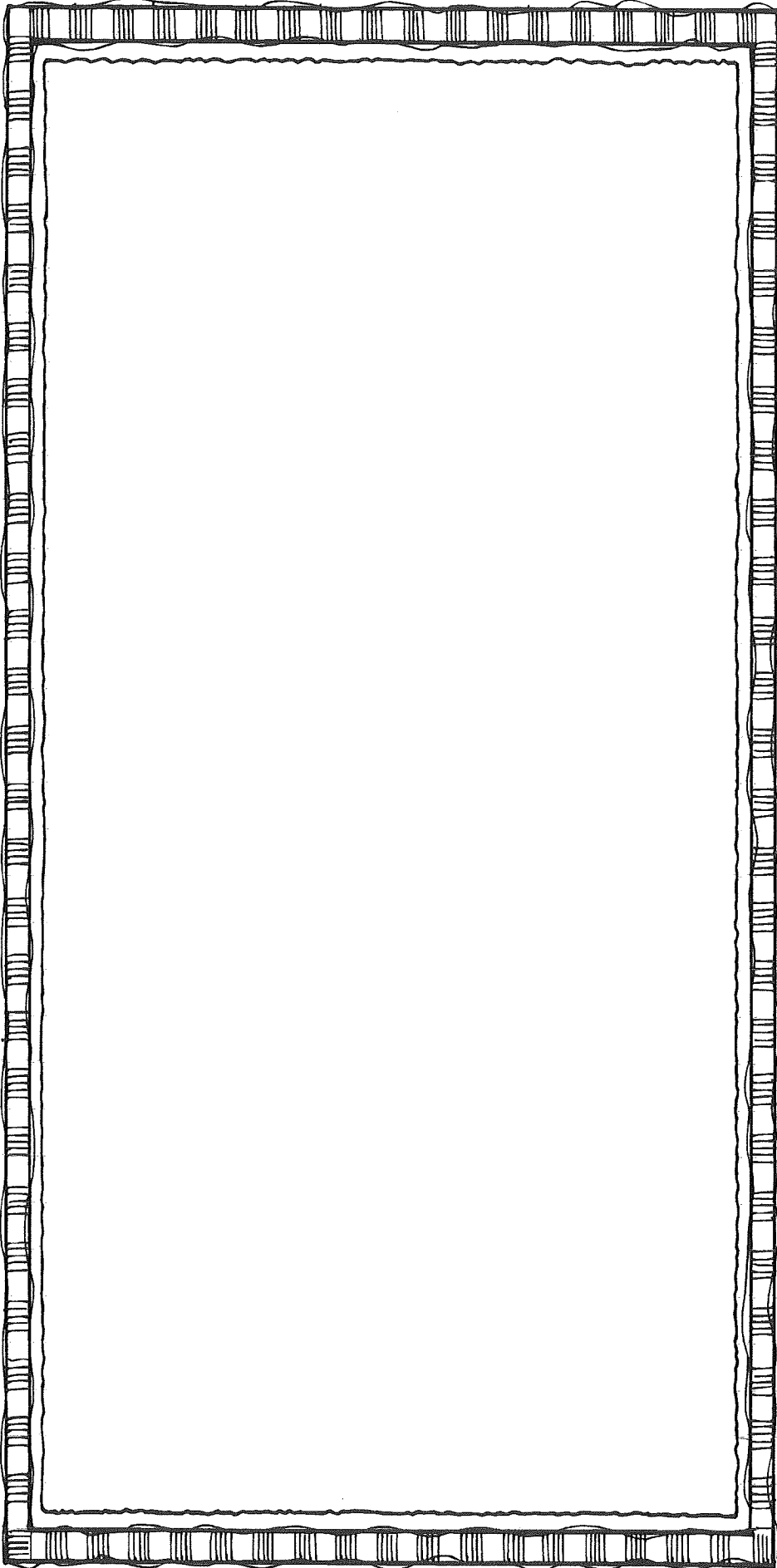

Four sets of horizontal writing lines. Each set consists of a solid top line, a dashed middle line, and a solid bottom line, providing a guide for letter height and placement.

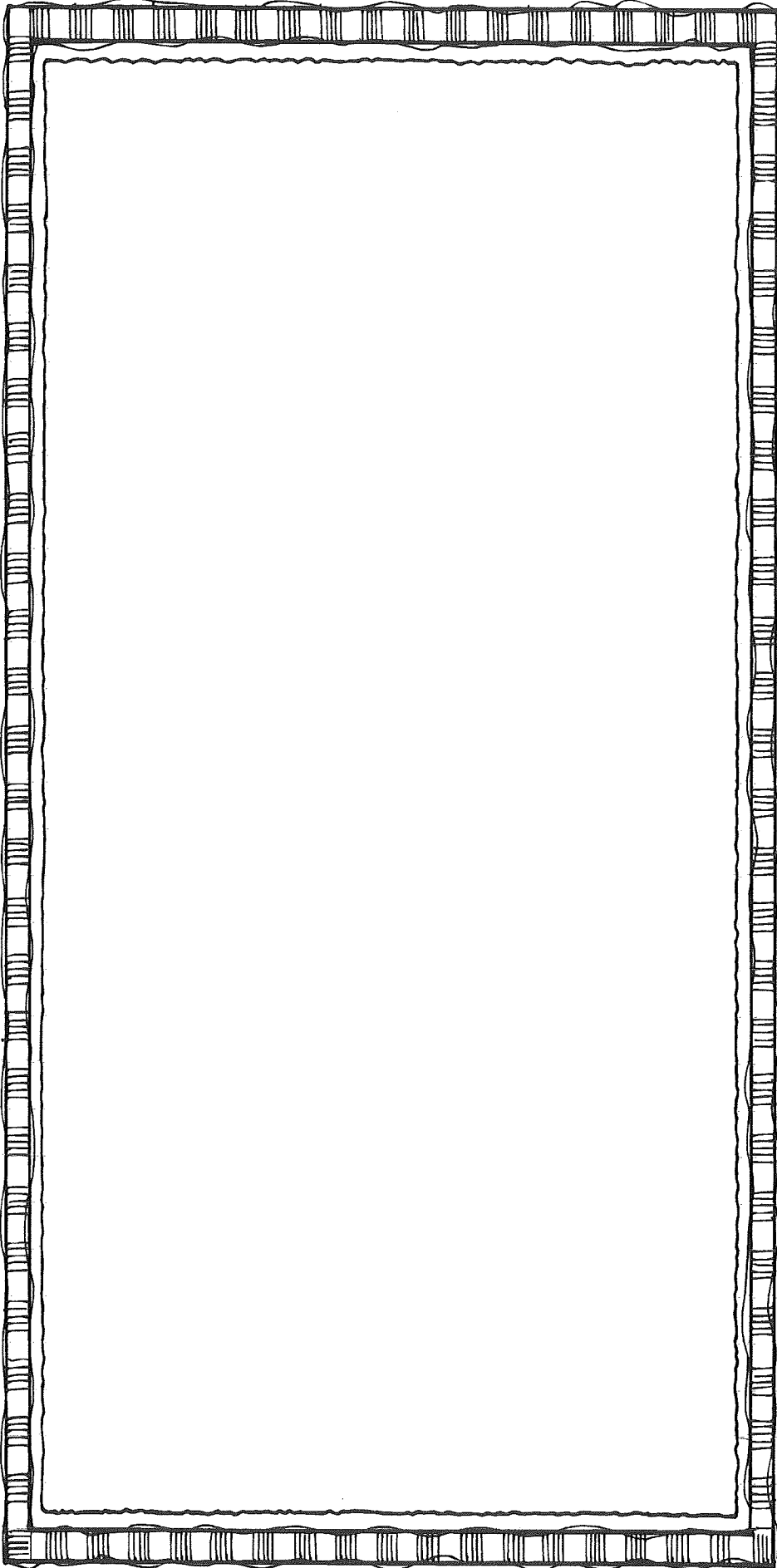

Four sets of horizontal writing lines. Each set consists of a solid top line, a dashed middle line, and a solid bottom line, providing a guide for letter height and placement.

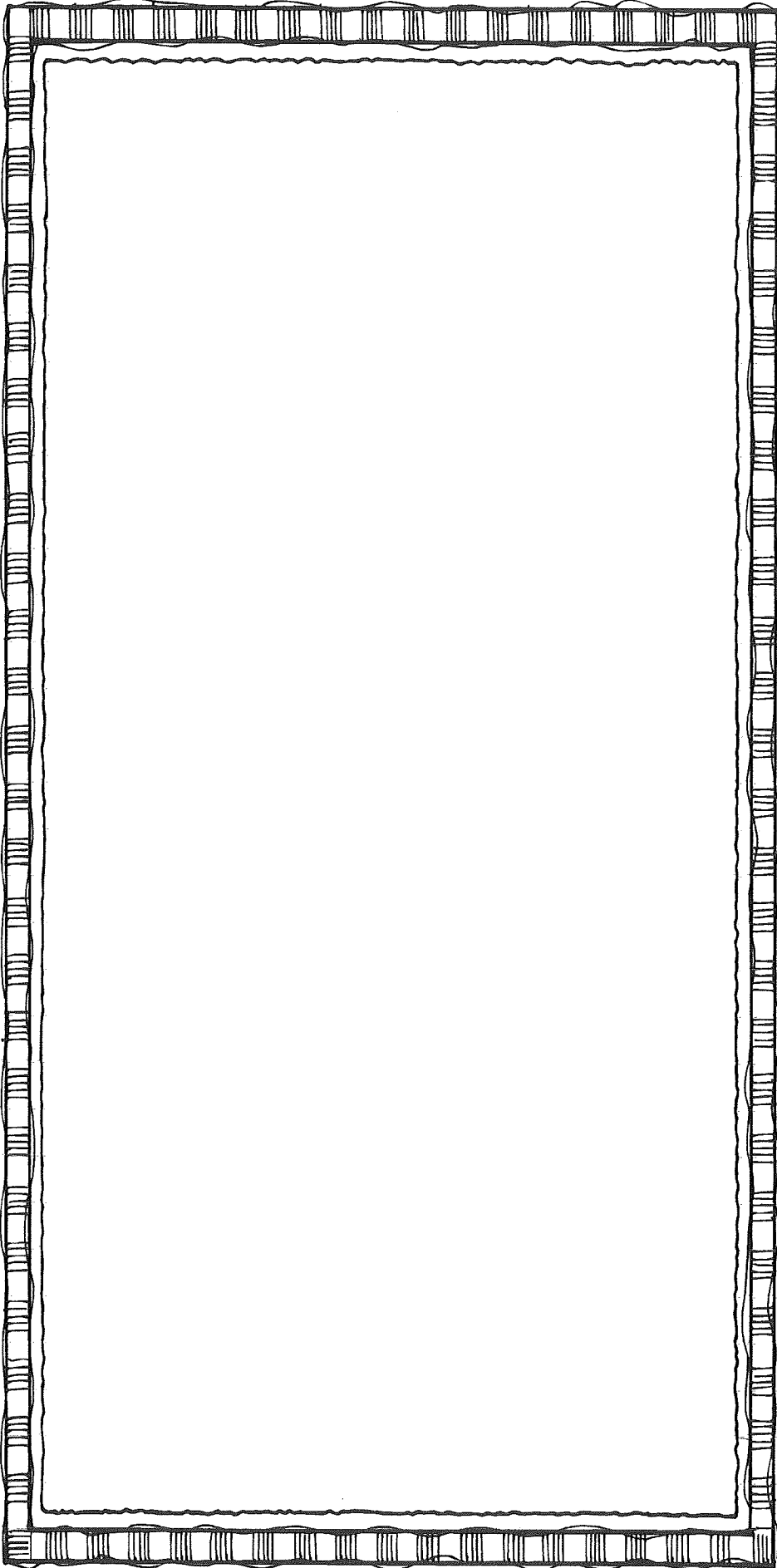

Handwriting practice lines consisting of four sets of horizontal lines. Each set includes a solid top line, a dashed middle line, and a solid bottom line, providing a guide for letter height and placement.

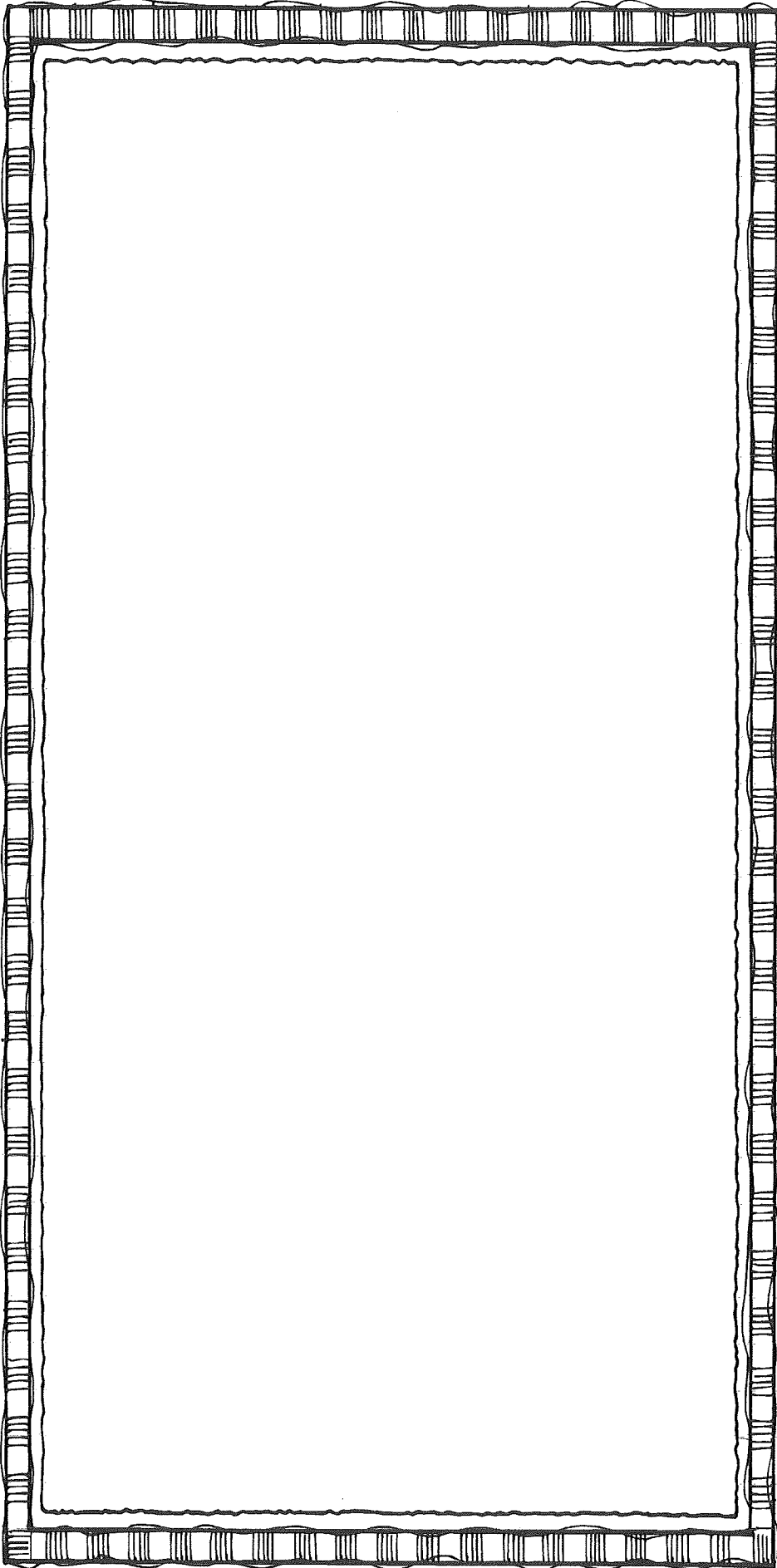

Handwriting practice lines consisting of four sets of horizontal lines. Each set includes a solid top line, a dashed middle line, and a solid bottom line.

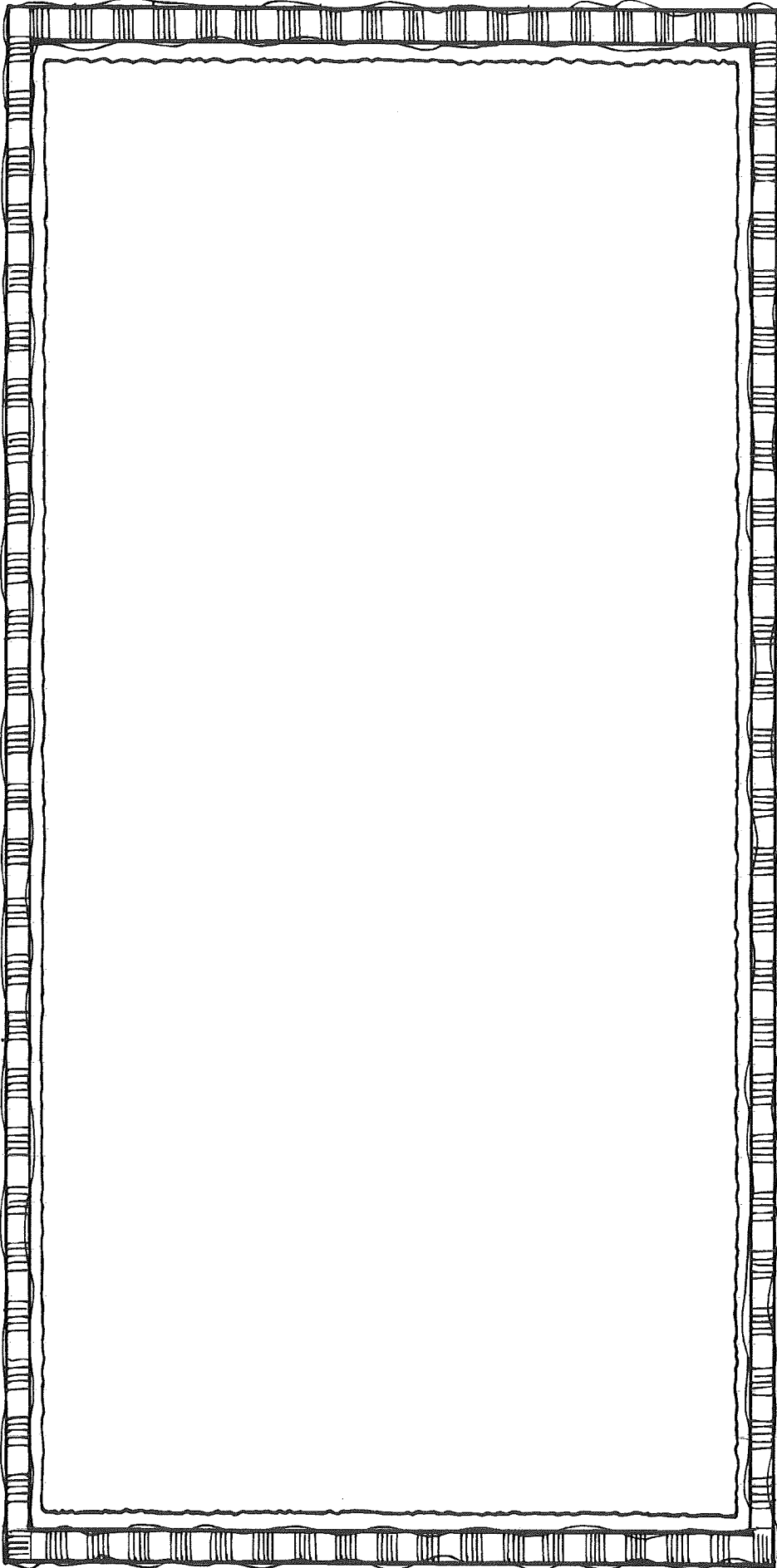

Handwriting practice lines consisting of four sets of horizontal lines. Each set includes a solid top line, a dashed middle line, and a solid bottom line.

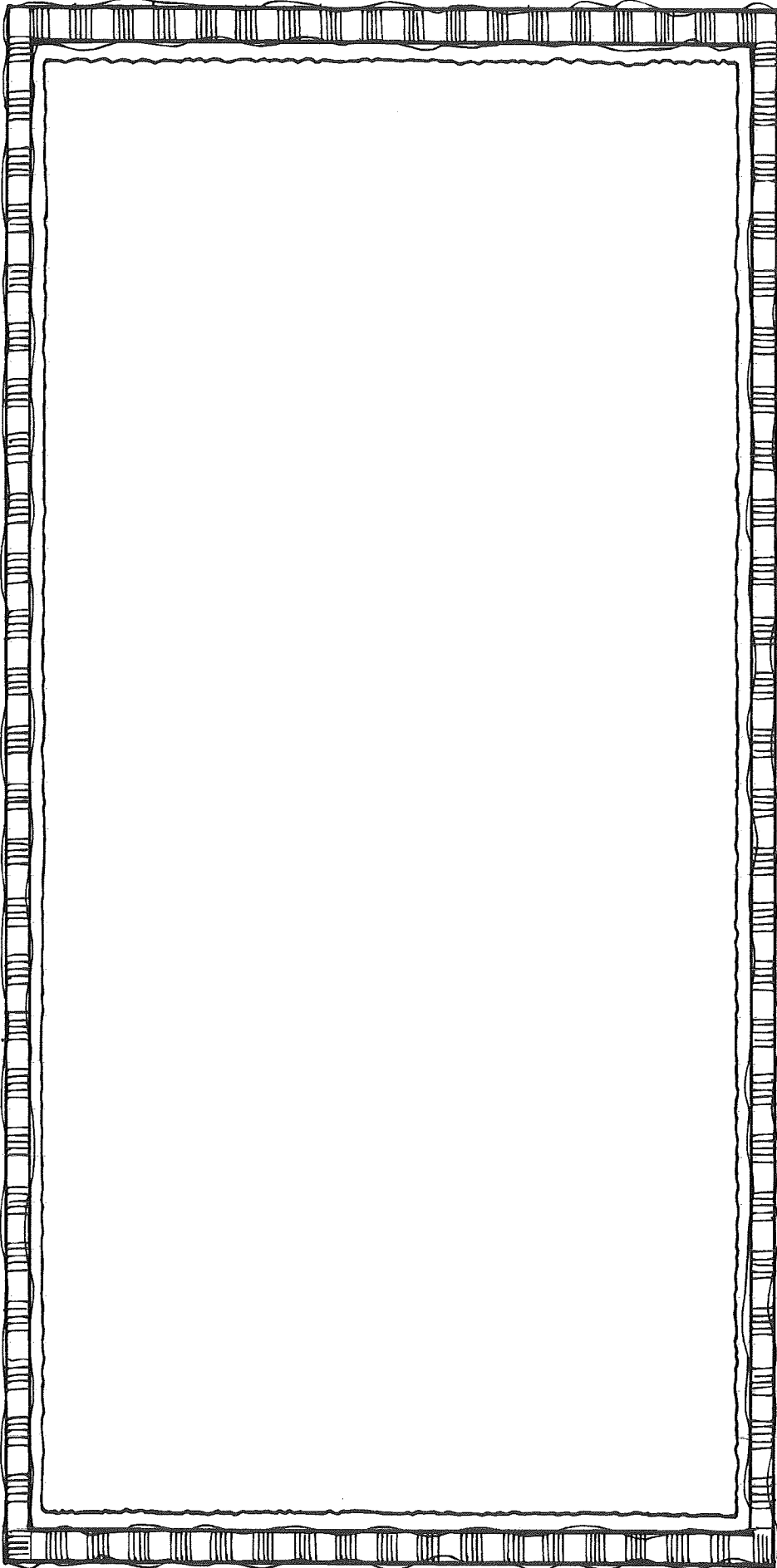

Handwriting practice lines consisting of four sets of horizontal lines. Each set includes a solid top line, a dashed middle line, and a solid bottom line, providing a guide for letter height and placement.

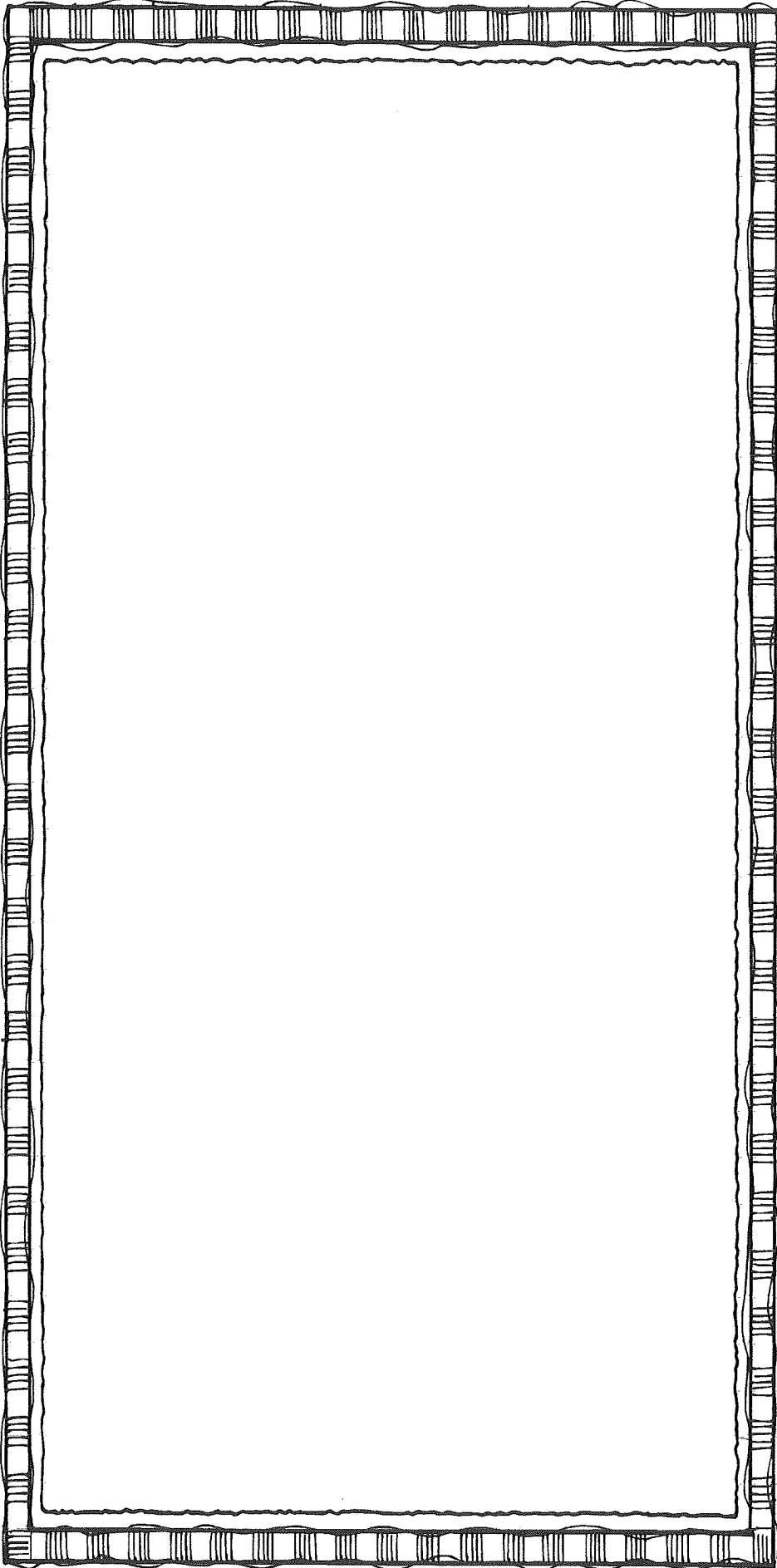

Handwriting practice lines consisting of four sets of horizontal lines. Each set includes a solid top line, a dashed middle line, and a solid bottom line, providing a guide for letter height and placement.

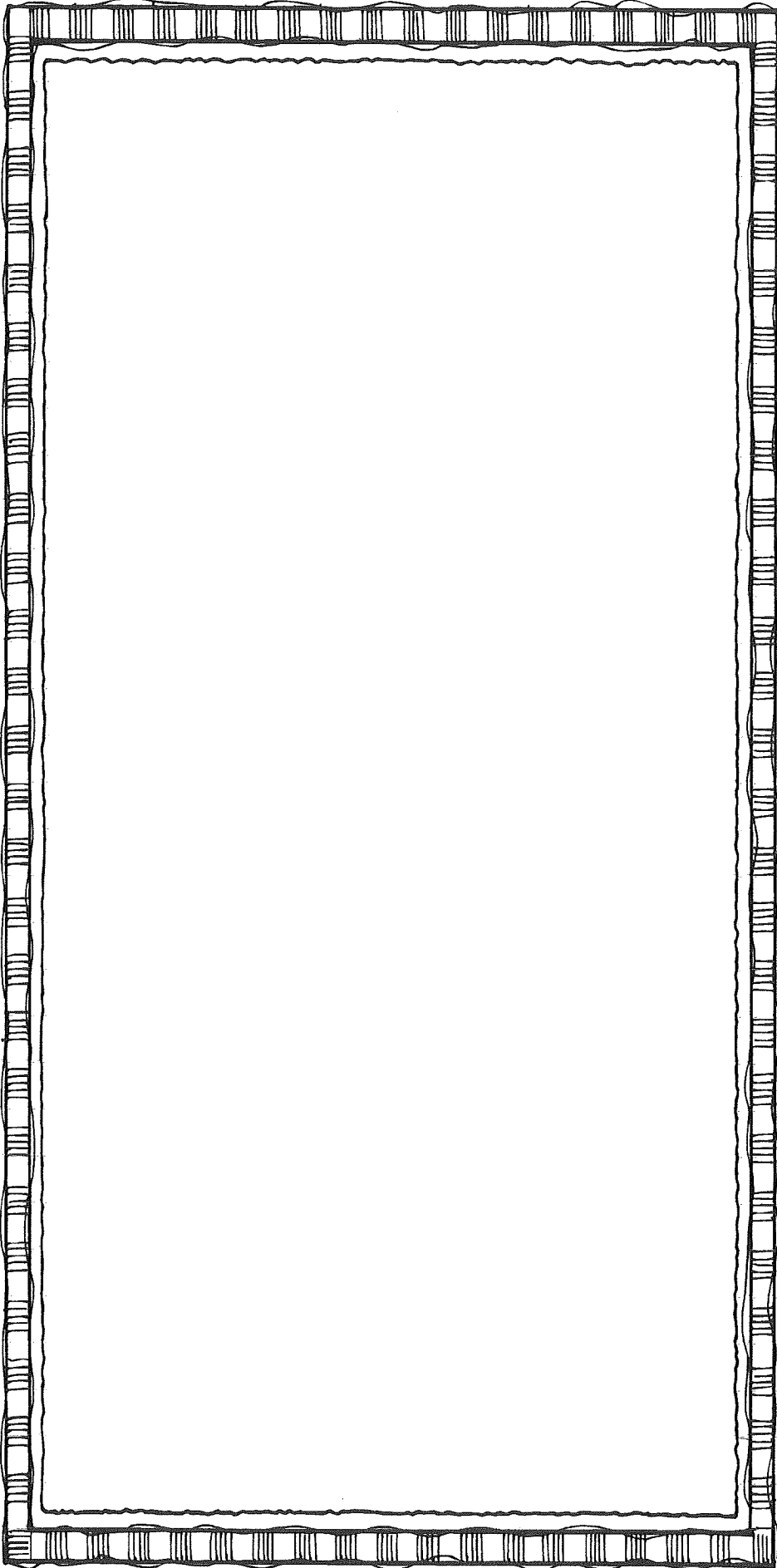

Handwriting practice lines consisting of four sets of horizontal lines. Each set includes a solid top line, a dashed middle line, and a solid bottom line, providing a guide for letter height and placement.

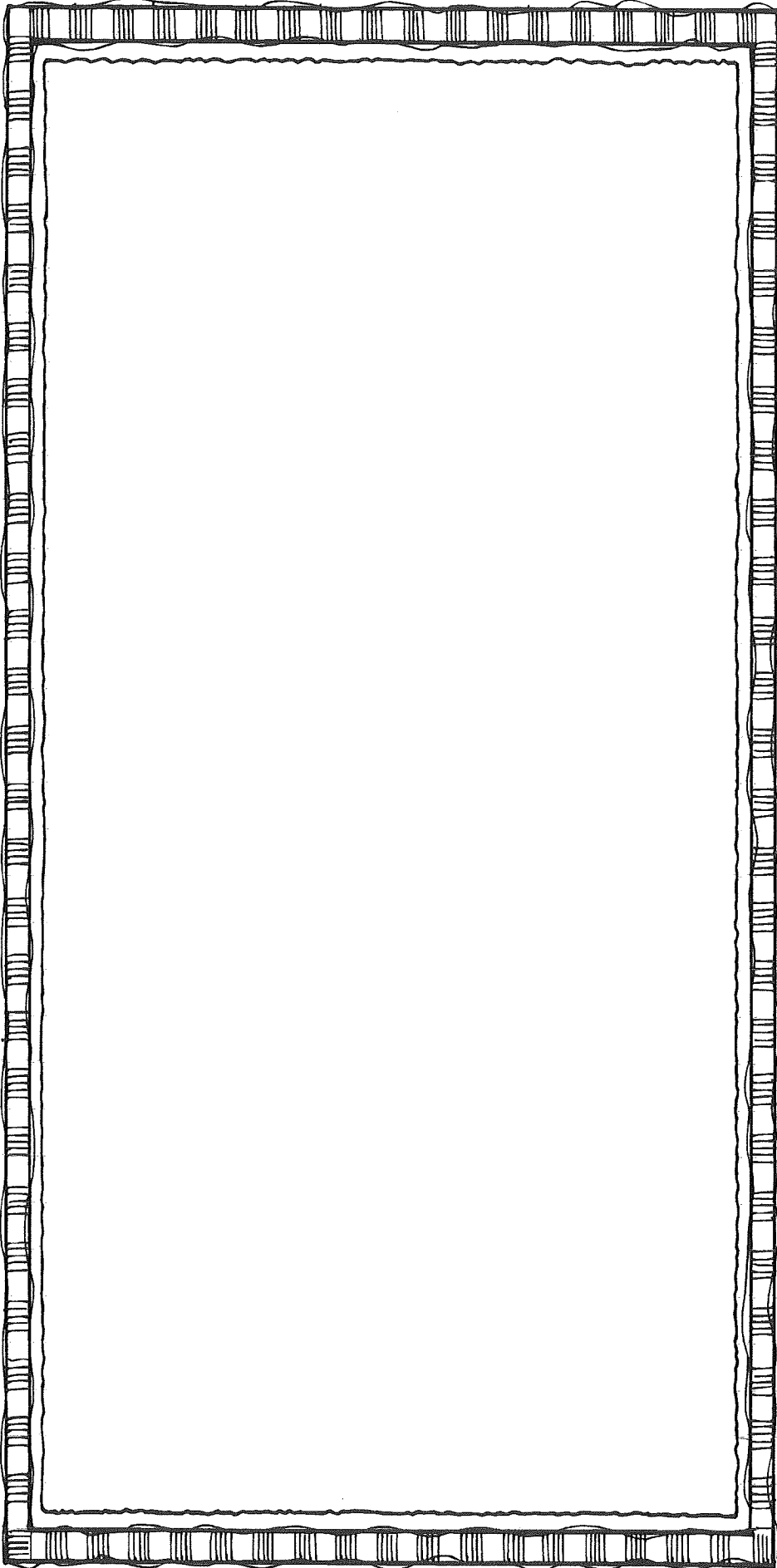

Handwriting practice lines consisting of four sets of horizontal lines. Each set includes a solid top line, a dashed middle line, and a solid bottom line, providing a guide for letter height and placement.

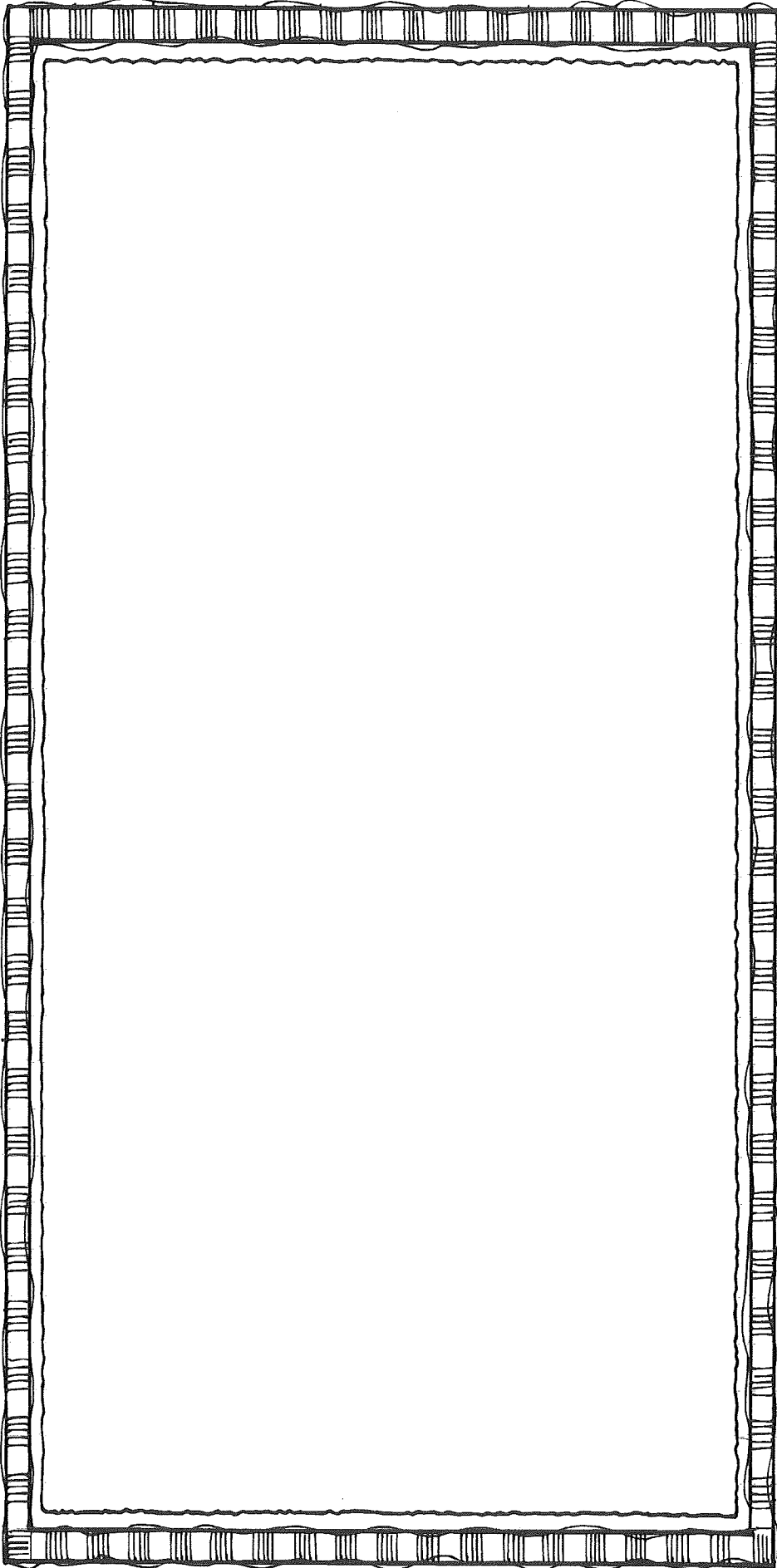

Handwriting practice lines consisting of four sets of horizontal lines. Each set includes a solid top line, a dashed middle line, and a solid bottom line, providing a guide for letter height and placement.

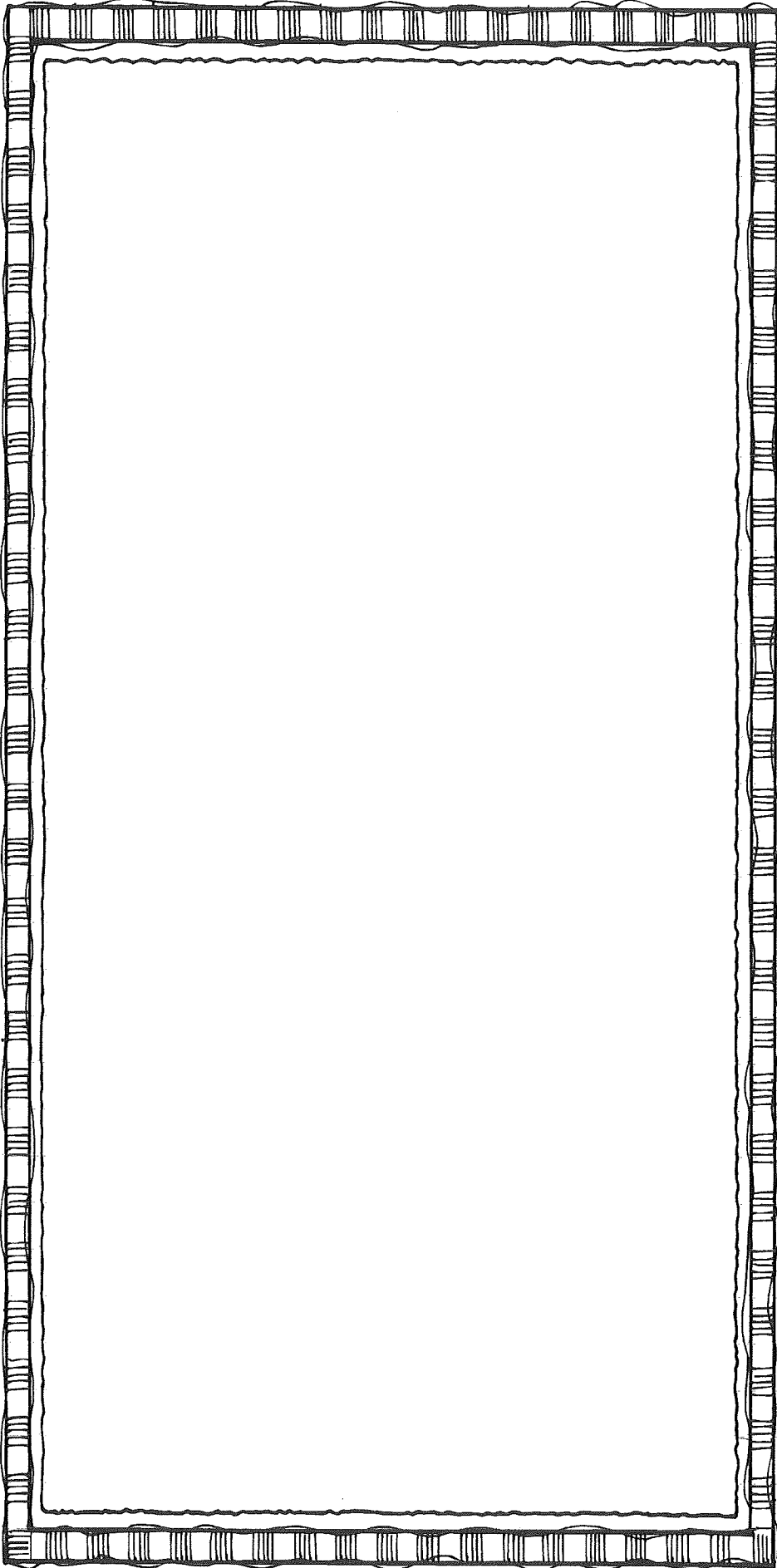

Four sets of horizontal writing lines. Each set consists of a solid top line, a dashed middle line, and a solid bottom line, providing a guide for letter height and placement.

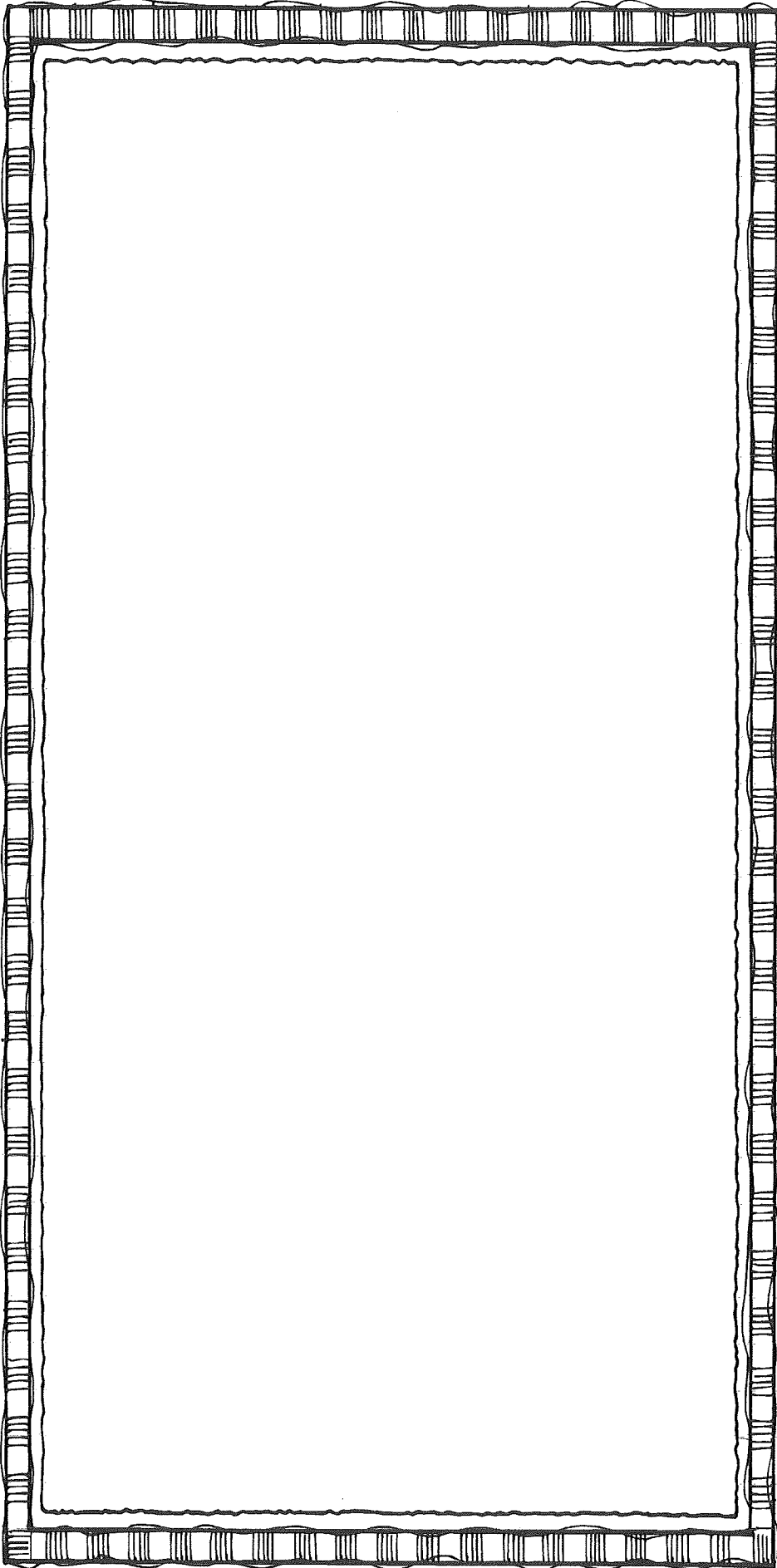

Handwriting practice lines consisting of four sets of horizontal lines. Each set includes a solid top line, a dashed middle line, and a solid bottom line, providing a guide for letter height and placement.

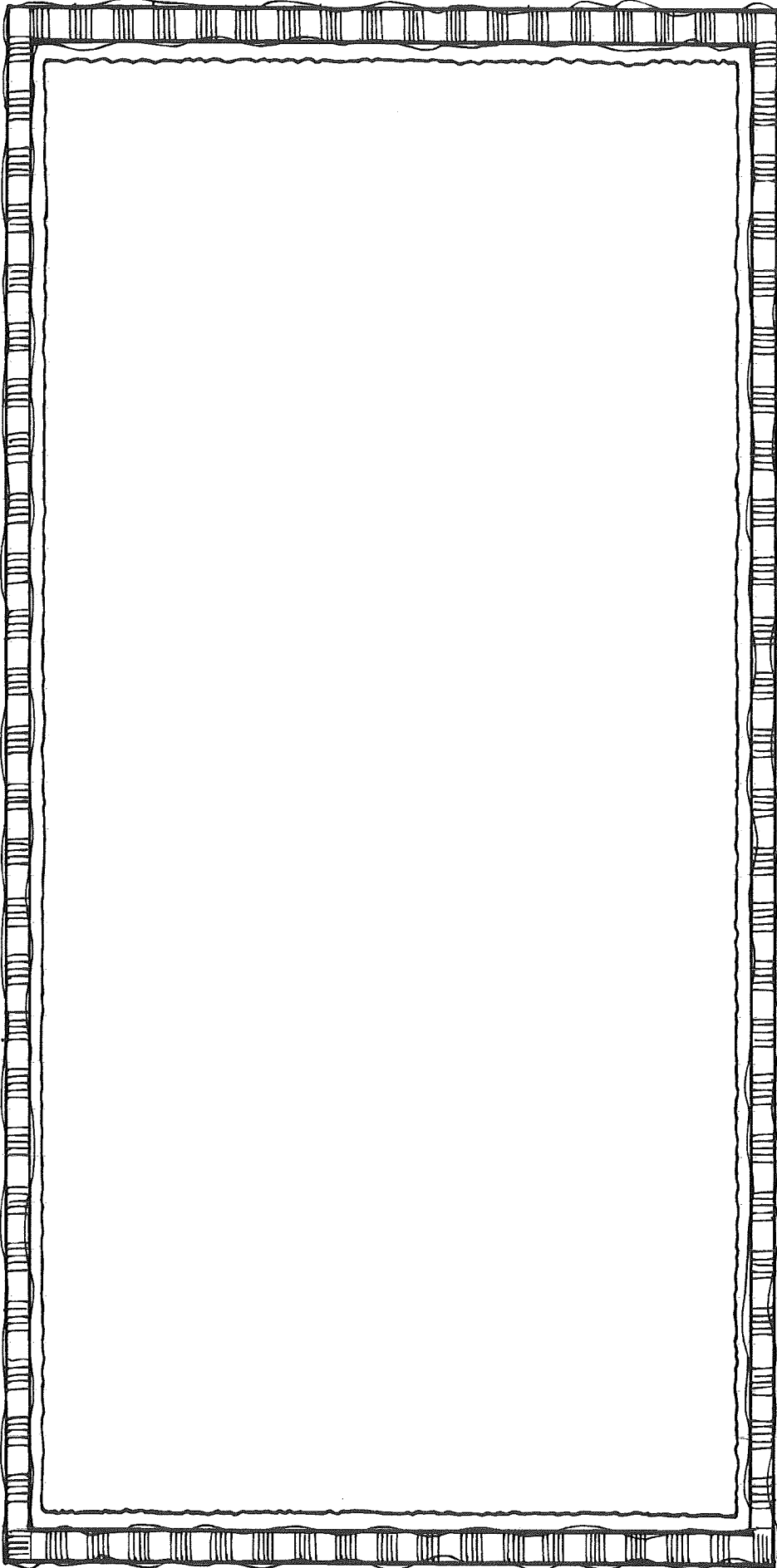

Handwriting practice lines consisting of four sets of horizontal lines. Each set includes a solid top line, a dashed middle line, and a solid bottom line, providing a guide for letter height and placement.

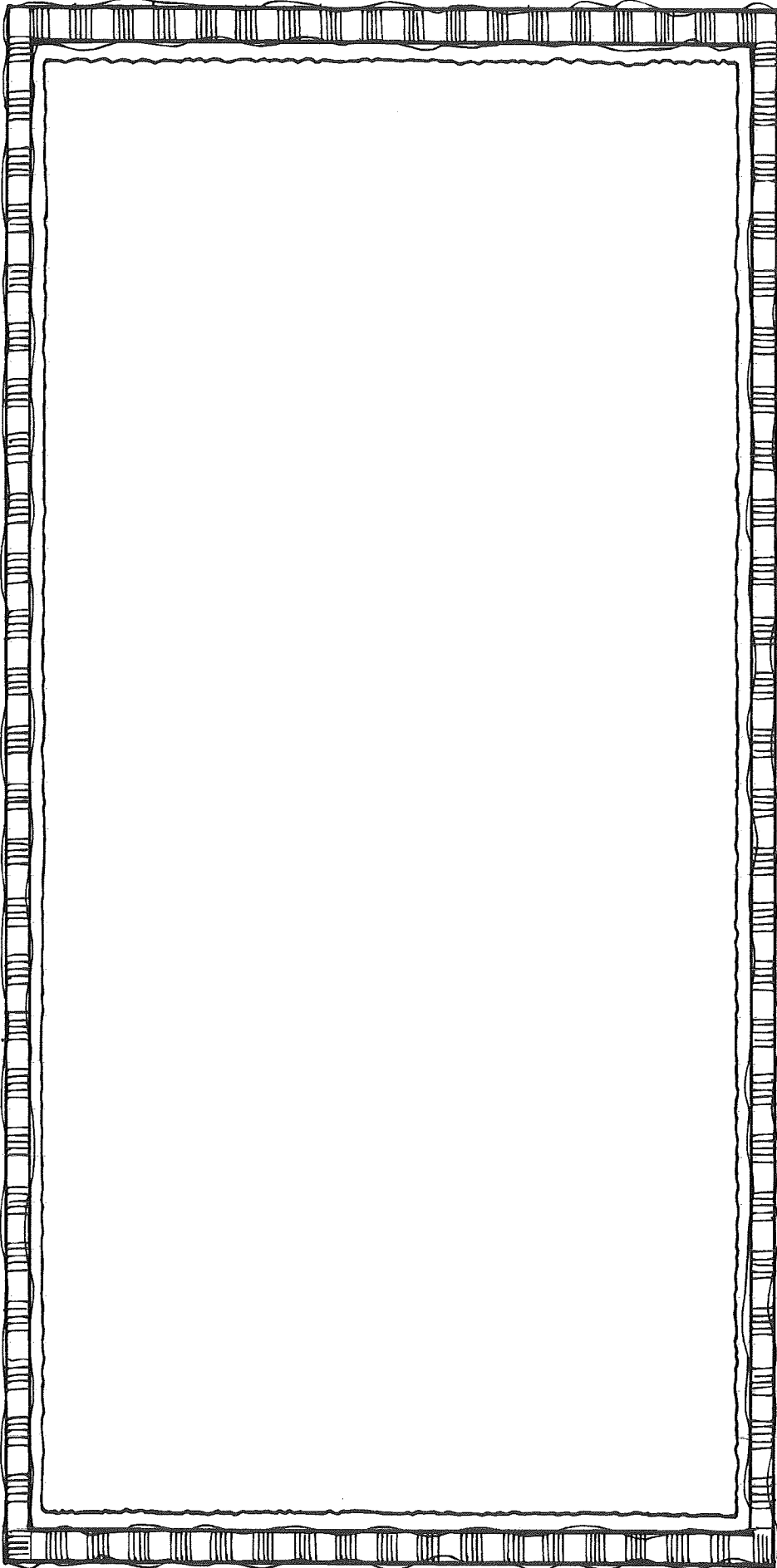

Handwriting practice lines consisting of four sets of horizontal lines. Each set includes a solid top line, a dashed middle line, and a solid bottom line, providing a guide for letter height and placement.

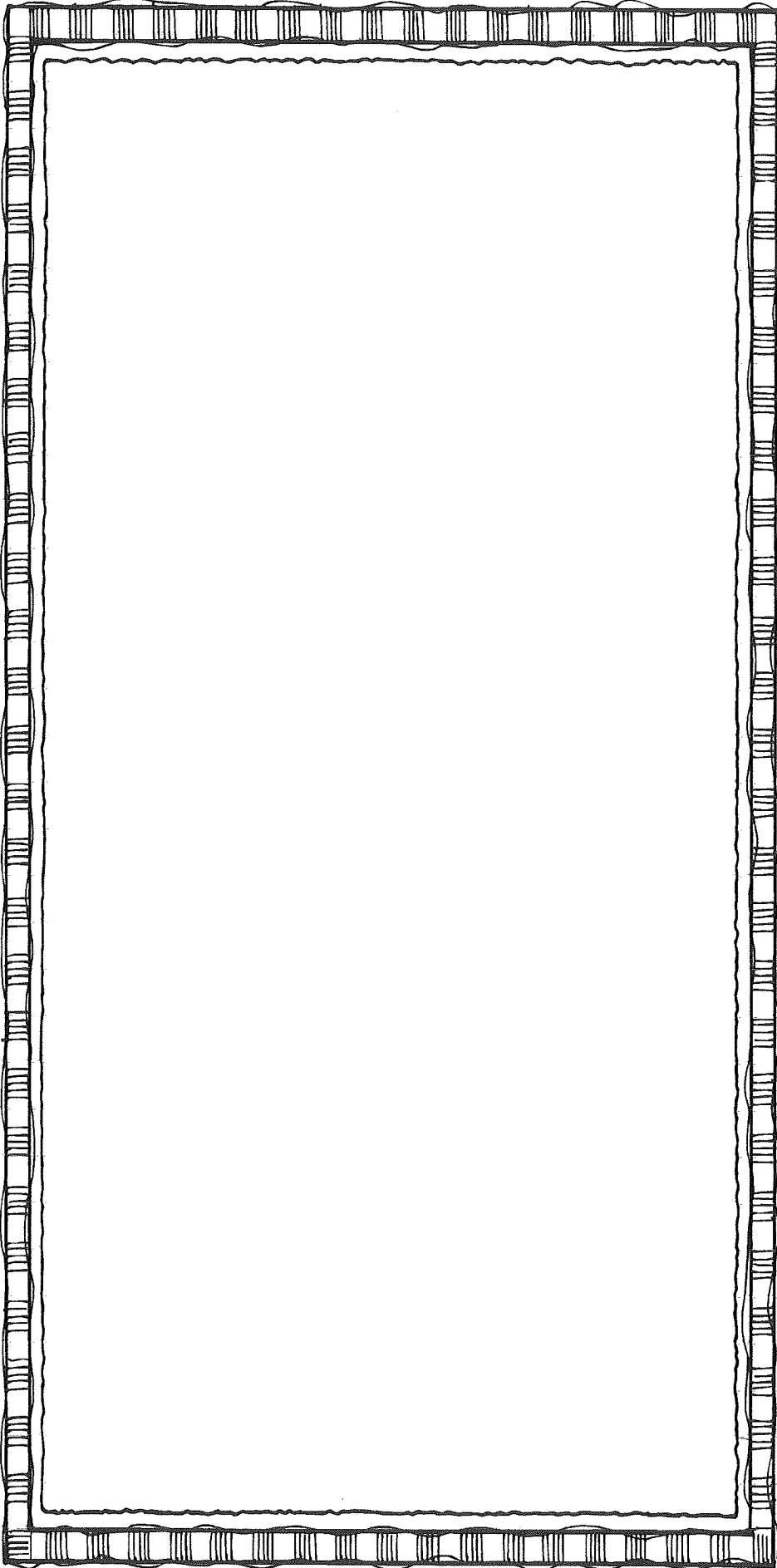

Handwriting practice lines consisting of four sets of horizontal lines. Each set includes a solid top line, a dashed middle line, and a solid bottom line, providing a guide for letter height and placement.

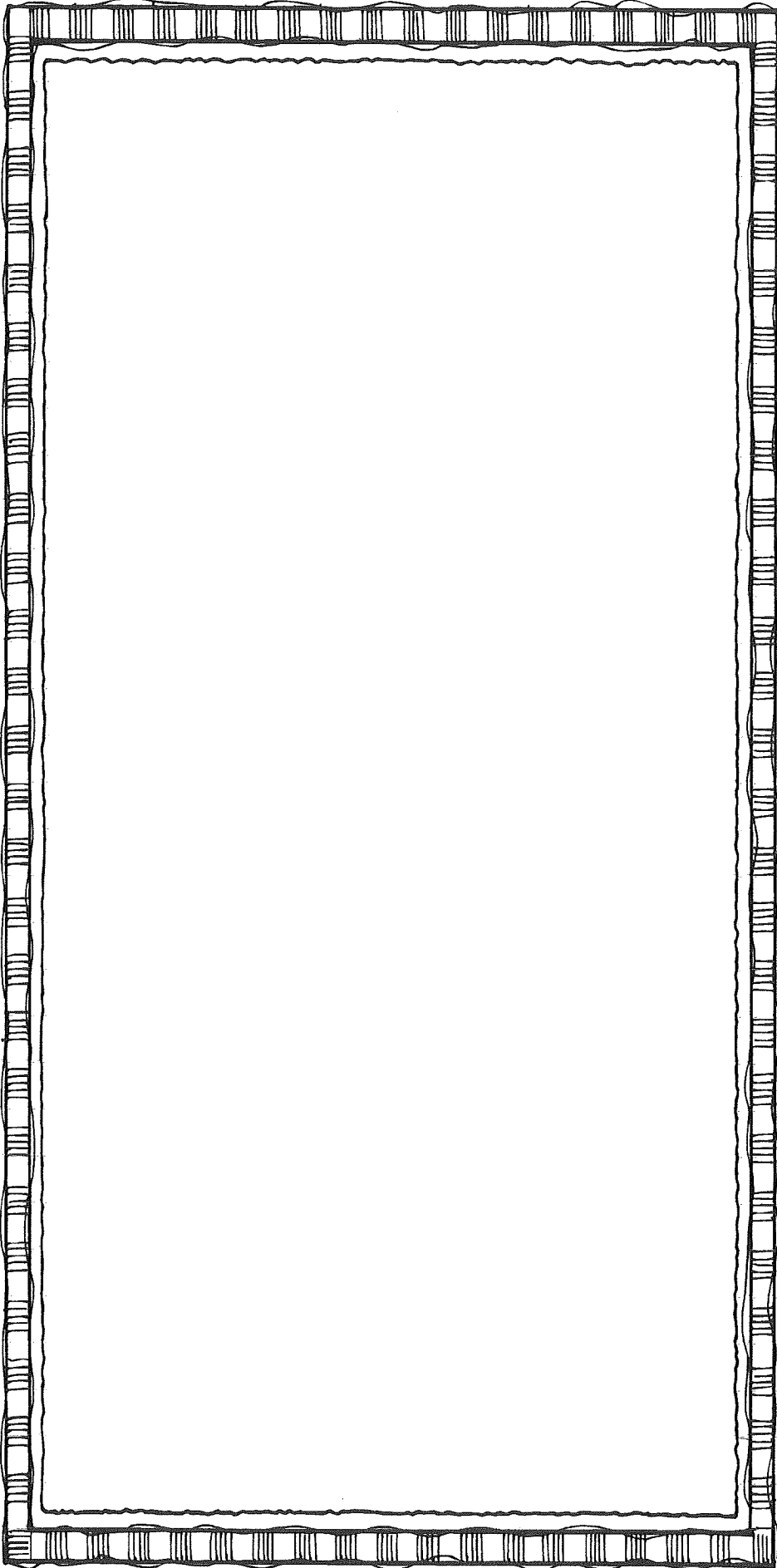

Handwriting practice lines consisting of four sets of horizontal lines. Each set includes a solid top line, a dashed middle line, and a solid bottom line, providing a guide for letter height and placement.

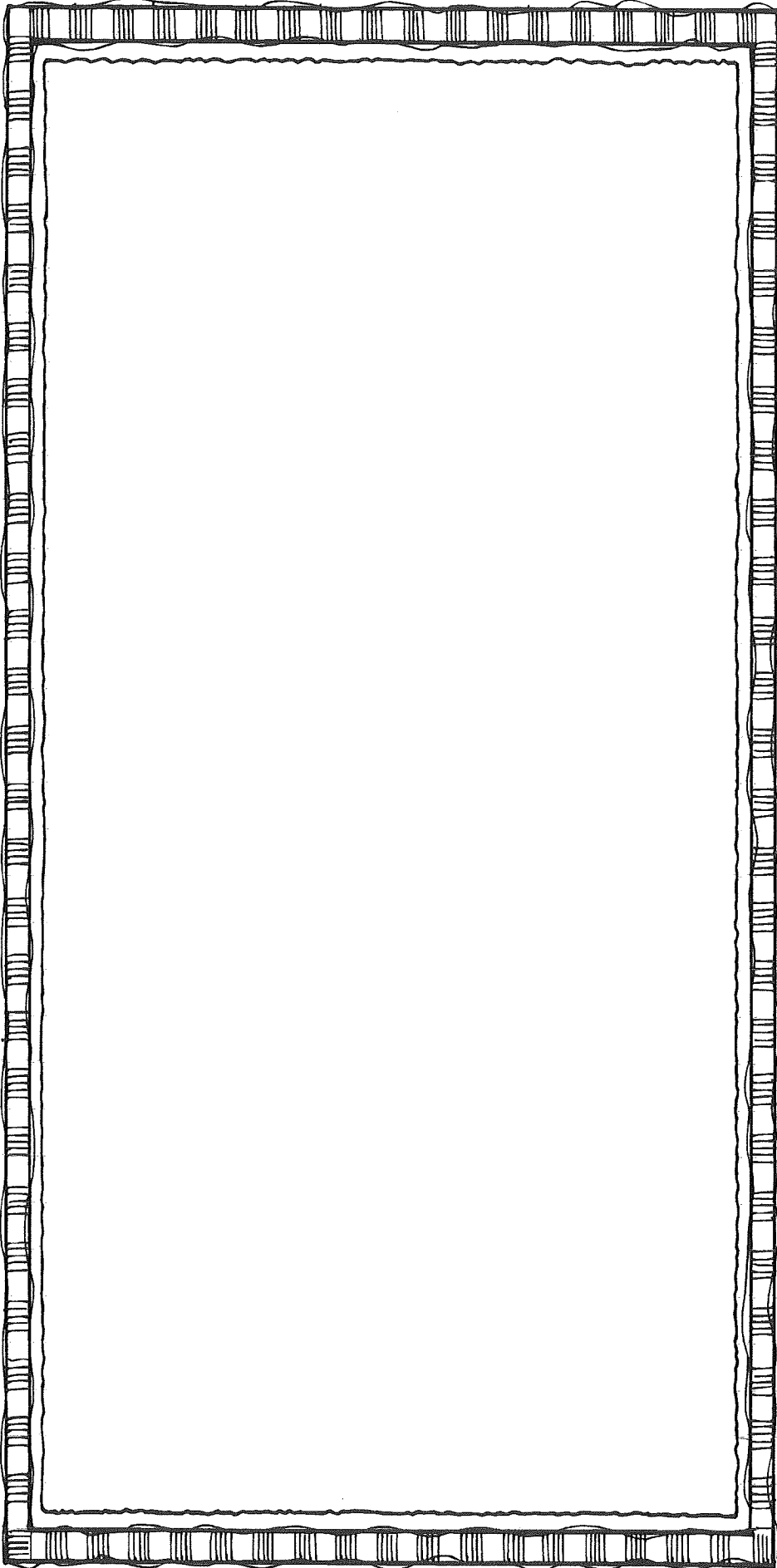

Handwriting practice lines consisting of four sets of horizontal lines. Each set includes a solid top line, a dashed middle line, and a solid bottom line, providing a guide for letter height and placement.



Penmanship/ El arte de escribir

Handwriting Practice

Letter Formation and Spacing

When teaching handwriting, focus on letter formation, letter size, letter and word spacing, and pencil grip and body posture. Begin with teaching the starting and stopping point of each letter. You can model this by tracing the letters with your finger.

For letter size, the following lowercase letters are half the size of letters with ascenders and descenders: **a, c, e, i, m, n, o, r, s, u, v, w, x, z**. Letters with ascenders are **b, d, f, h, k, l**, and **t**. Letters with descenders are **g, j, p, q**, and **y**. Uppercase letters are the same height as ascenders.

The space between each letter in a word should be the same, and the space between each word in a sentence should be consistent. You can use your pinkie finger to measure the correct spacing between words.

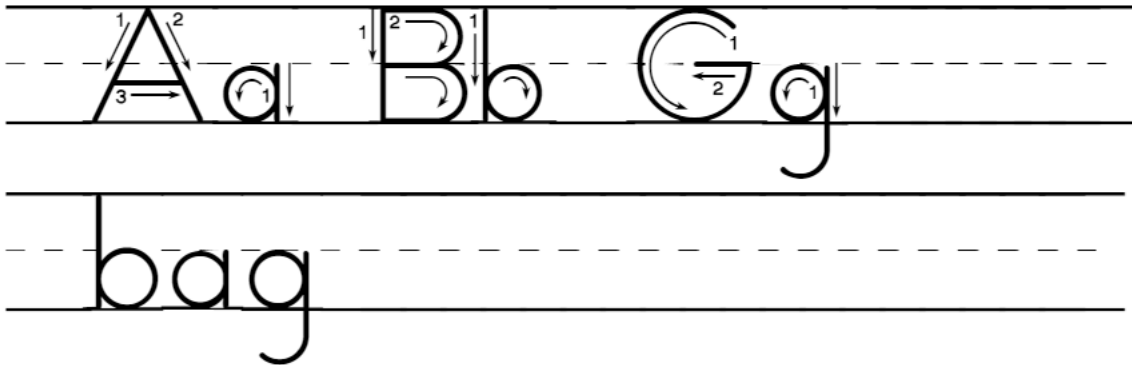

Práctica de escritura de molde

Trazado de letras y espaciado

Cuando enseñe la escritura a mano, concéntrese en la formación de letras, el tamaño, el espacio entre letras y palabras, el agarre del lápiz y la postura del cuerpo. Comience enseñando del punto inicial hasta el final de cada letra. Puede demostrar esto trazando las letras con su dedo.

Para el tamaño de las letras, las siguientes letras minúsculas son la mitad del tamaño de las letras con ascendentes y descendentes: a, c, e, i, m, n, ñ, o, r, s, u, v, w, x, z. Las letras con ascendentes son b, d, f, h, k, l y t. Las letras con descendentes son g, j, p, q y y. Las letras mayúsculas tienen la misma altura que las ascendentes.

El espacio entre cada letra en una palabra debe ser el mismo, y el espacio entre cada palabra en una oración debe ser consistente. Puedes usar tu dedo meñique para medir el espacio correcto entre las palabras.

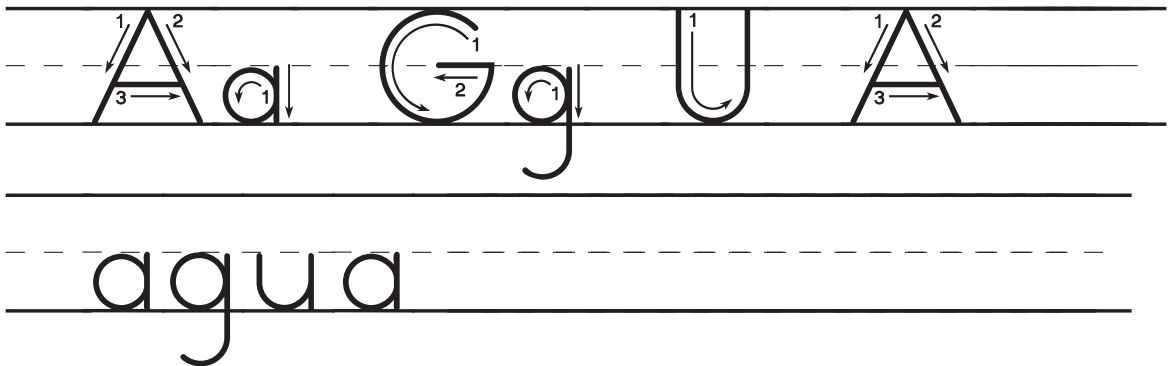

Proper Handwriting Grip and Body Posture



Tripod Grip

For the tripod grip, hold your pencil with your thumb, index finger, and middle finger.

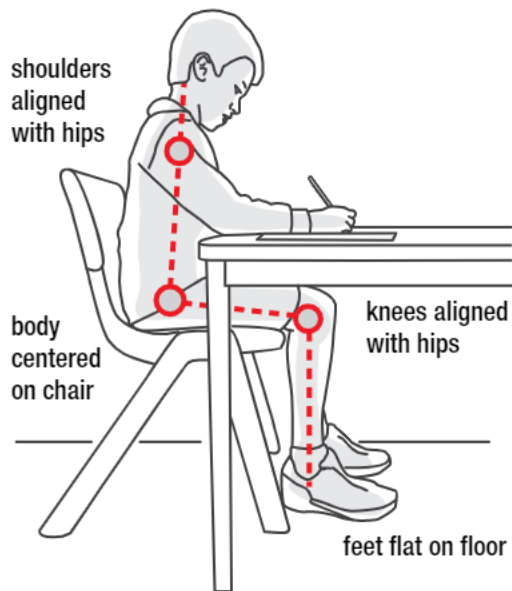

Proper Posture

For good posture while writing, sit with your feet flat on the floor and your bottom in the center of your seat.

Agarre adecuado del lápiz y postura del cuerpo



Agarre de trípode

Para el agarre de trípode, sostenga el lápiz con el pulgar, el índice y el dedo del medio.

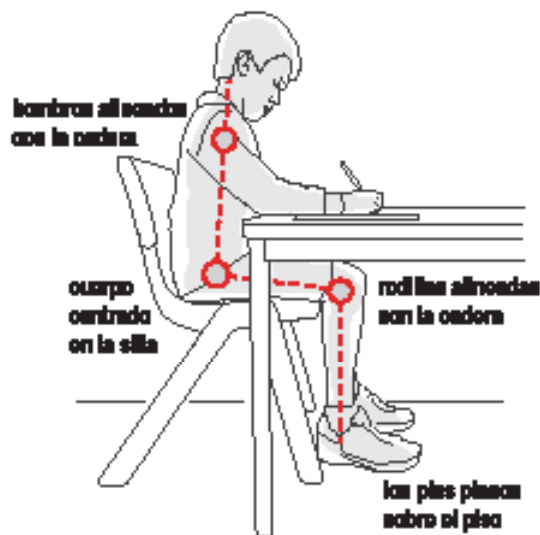

Postura adecuada

Para una buena postura mientras escribe, siéntese con los pies apoyados en el piso y su trasero en el centro del asiento.

Forming Letters

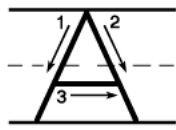

Uppercase **A**: slant left down, lift, slant right down, lift, slide across in the middle

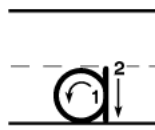

Lowercase **a**: circle back, lift, pull down

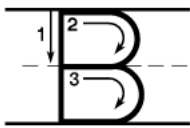

Uppercase **B**: pull down, push up to the top, curve forward, slide left, curve forward, slide left

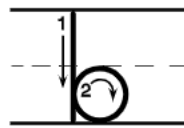

Lowercase **b**: pull down, push up, circle forward

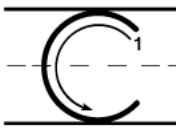

Uppercase **C**: circle back and open

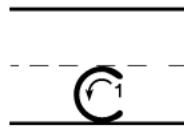

Lowercase **c**: circle back and open

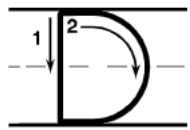

Uppercase **D**: pull down, lift, curve forward

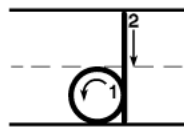

Lowercase **d**: circle back, push up, pull down

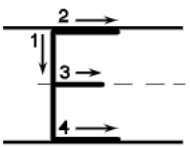

Uppercase **E**: pull down, lift, top slide right, lift, middle slide right, lift, bottom slide right

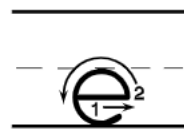

Lowercase **e**: slide right, circle back

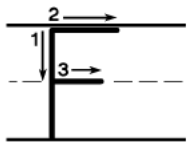

Uppercase **F**: pull down, lift, top slide right, lift, middle slide right

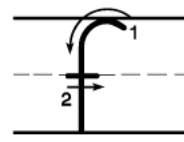

Lowercase **f**: curve back from the top, lift, cross in the middle

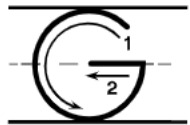

Uppercase **G**: circle back, slide left in the middle

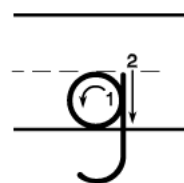

Lowercase **g**: circle back, push up, pull down, curve back

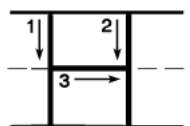

Uppercase **H**: pull down, lift, pull down, lift, slide across in the middle

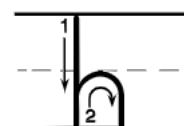

Lowercase **h**: pull down, push up, curve forward, pull down

Trazado de las letras

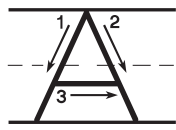

Mayúscula **A**: diagonal izquierda hacia abajo, levanta, diagonal derecha hacia abajo, levanta, traza una línea en el centro

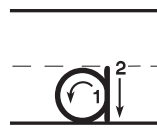

Minúscula **a**: haz un círculo hacia atrás, levanta, traza hacia abajo

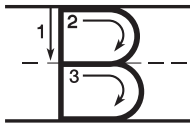

Mayúscula **B**: traza hacia abajo, levanta y vuelve arriba, haz un semicírculo de derecha a izquierda hasta el medio y repítelo desde el medio hasta abajo

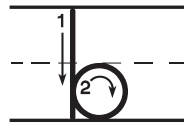

Minúscula **b**: traza hacia abajo, levanta y añade un círculo

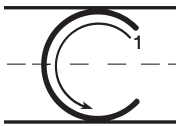

Mayúscula **C**: haz un semicírculo hacia atrás y déjalo abierto

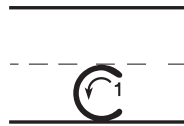

Minúscula **c**: haz un semicírculo hacia atrás y déjalo abierto

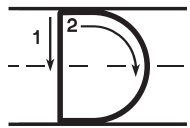

Mayúscula **D**: traza hacia abajo, levanta, haz un semicírculo desde arriba hasta abajo

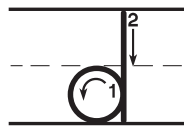

Minúscula **d**: haz un semicírculo de de derecha a izquierda, levanta, traza desde arriba hasta abajo

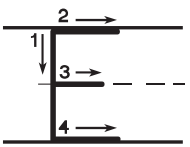

Mayúscula **E**: traza hacia abajo, levanta, traza arriba de izquierda a derecha, levanta, traza en el centro, levanta, traza abajo

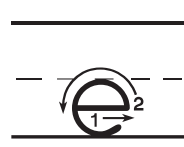

Minúscula **e**: haz un trazo de izquierda y al final haz un semicírculo de derecha a izquierda

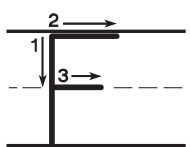

Mayúscula **F**: traza hacia abajo, levanta, traza arriba de izquierda a derecha, levanta, en el medio haz un trazo más corto que el de arriba

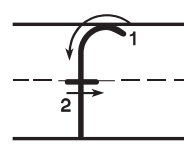

Minúscula **f**: curva hacia atrás desde arriba, levanta, traza en el medio

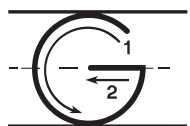

Mayúscula **G**: haz un semicírculo desde arriba y en el medio trazas hacia la izquierda

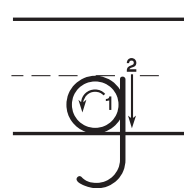

Minúscula **g**: haz un círculo, levanta, traza hacia abajo y curva hacia la izquierda

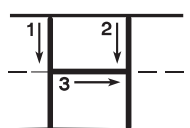

Mayúscula **H**: traza hacia abajo, levanta, traza hacia abajo, levanta, traza en el medio

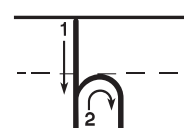

Minúscula **h**: traza hacia abajo, levanta, curva hacia la derecha desde el medio y traza hacia abajo

Forming Letters (continued)

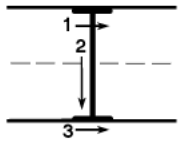

Uppercase **I**: cross the top, pull down, cross the bottom

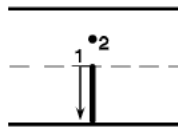

Lowercase **i**: pull down, dot above the top

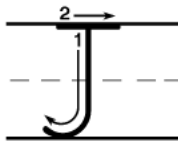

Uppercase **J**: pull down, curve back, lift, cross the top

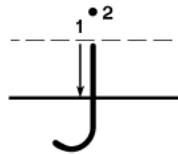

Lowercase **j**: pull down, curve back, dot above the top

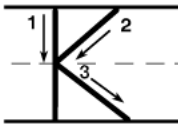

Uppercase **K**: pull down, lift, slant in, slant out

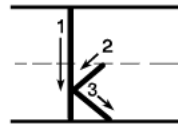

Lowercase **k**: pull down, lift, slant in, slant out

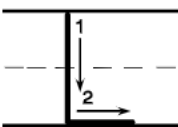

Uppercase **L**: pull down, slide right

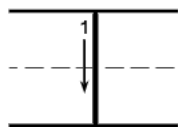

Lowercase **l**: pull down

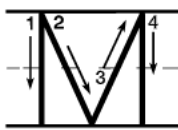

Uppercase **M**: pull down, lift, slant left down, slant up, pull down

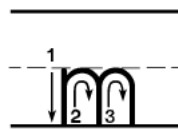

Lowercase **m**: pull down, push up, curve forward, pull down, push up, curve forward, pull down

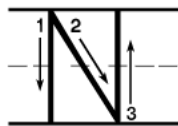

Uppercase **N**: pull down, lift, slant right down, push up

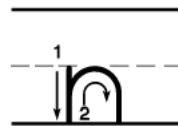

Lowercase **n**: pull down, push up, curve forward, pull down

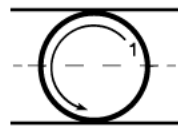

Uppercase **O**: circle around

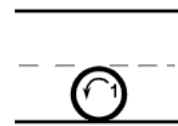

Lowercase **o**: circle around

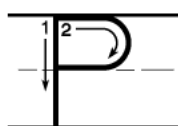

Uppercase **P**: pull down, lift, push up, curve forward, slide left

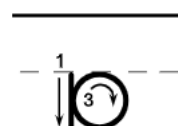

Lowercase **p**: pull down, push up, circle forward

Trazado de las letras (continuación)

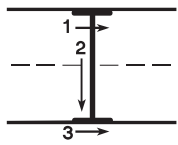

Mayúscula **I**: haz un tracito arriba de izquierda a derecha, traza hacia abajo desde el medio repite el tracito abajo

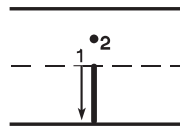

Minúscula **i**: traza hacia abajo, haz un punto en la parte superior del trazo

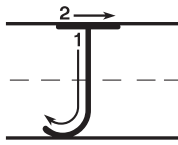

Mayúscula **J**: traza hacia abajo, curva hacia la izquierda, levanta, haz un tracito en la parte superior

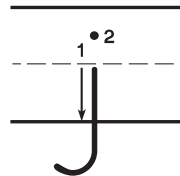

Minúscula **j**: traza hacia abajo, curva hacia la izquierda, haz un punto en la parte superior del trazo

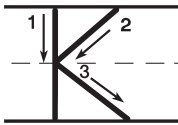

Mayúscula **K**: traza hacia abajo, levanta, diagonal desde afuera hacia el medio y desde el medio hacia afuera

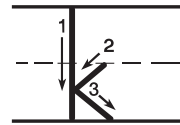

Minúscula **k**: traza hacia abajo, levanta, diagonal desde afuera hacia más abajo del medio y desde allí hacia afuera

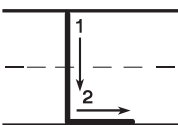

Mayúscula **L**: traza hacia abajo y desde abajo traza de izquierda a derecha

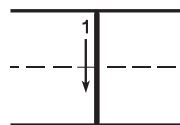

Minúscula **l**: traza hacia abajo

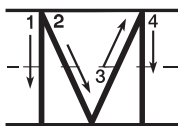

Mayúscula **M**: traza hacia abajo, levanta, diagonal desde arriba del primer trazo hasta abajo, diagonal desde allí hasta arriba, traza hacia abajo

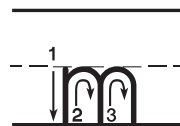

Minúscula **m**: traza hacia abajo, levanta, curve de izquierda a derecha, traza hacia abajo, levanta, curva de izquierda a derecha, traza hacia abajo

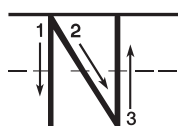

Mayúscula **N**: traza hacia abajo, levanta, diagonal de izquierda a derecha hasta abajo, levanta, traza hacia abajo y conecta

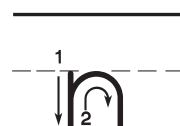

Minúscula **n**: traza hacia abajo, levanta, curva de izquierda a derecha, traza hacia abajo

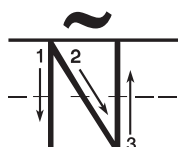

Mayúscula **Ñ**: traza hacia abajo, levanta, diagonal de izquierda a derecha hasta abajo, levanta, traza hacia abajo y conecta. Sobre la letra haz una curvita hacia arriba, hacia abajo, hacia arriba

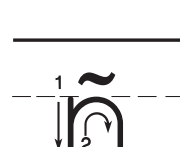

Minúscula **ñ**: traza hacia abajo, levanta, curva de izquierda a derecha, traza hacia abajo. Sobre la letra haz una curvita hacia arriba, hacia abajo, hacia arriba

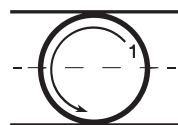

Mayúscula **O**: haz un círculo desde arriba hasta abajo

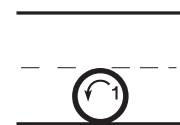

Minúscula **o**: haz un círculo desde el medio hasta abajo

Forming Letters (continued)

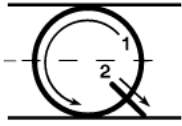

Uppercase **Q**: circle around, lift, slant right

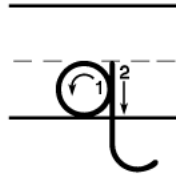

Lowercase **q**: circle back, push up, pull down, curve back

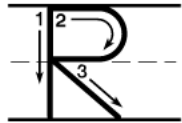

Uppercase **R**: pull down, lift, curve forward, slide left, slant right

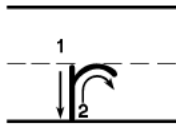

Lowercase **r**: pull down, push up, curve forward



Uppercase **S**: curve back, curve forward

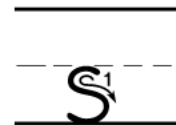

Lowercase **s**: curve back, curve forward

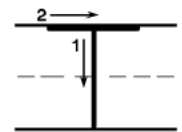

Uppercase **T**: pull down, lift, cross the top

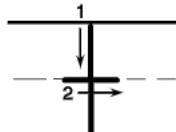

Lowercase **t**: pull down, lift, cross in the middle

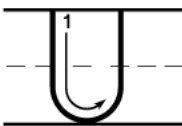

Uppercase **U**: pull down, curve forward, push up

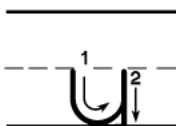

Lowercase **u**: pull down, curve forward, push up, pull down

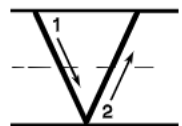

Uppercase **V**: slant right, slant up

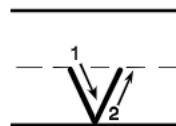

Lowercase **v**: slant right, slant up

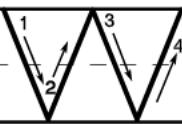

Uppercase **W**: slant right down, slant up, slant right down, slant up

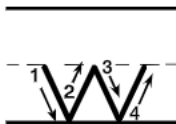

Lowercase **w**: slant right down, slant up, slant right down, slant up

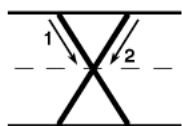

Uppercase **X**: slant right down, lift, slant left down

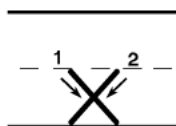

Lowercase **x**: slant right down, lift, slant left down

Trazado de las letras (continuación)

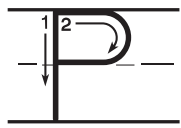

Mayúscula **P**: traza hacia abajo, levanta, haz un semicírculo desde arriba hasta el medio

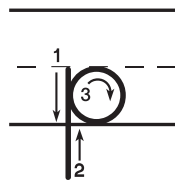

Minúscula **p**: traza hacia abajo, levanta, haz un círculo de izquierda a derecha

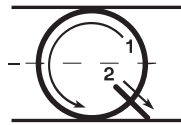

Mayúscula **Q**: haz un círculo desde arriba hasta abajo y traza una diagonal pequeña en la parte inferior derecha

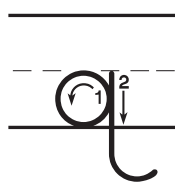

Minúscula **q**: haz un círculo de derecha a izquierda, levanta, traza hacia abajo y curva a la derecha

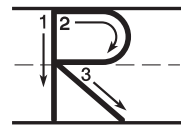

Mayúscula **R**: traza hacia abajo, levanta, haz un semicírculo desde arriba hasta el medio y traza una diagonal desde el medio hacia la derecha

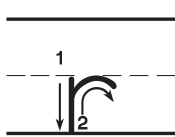

Minúscula **r**: traza hacia abajo, levanta, curva arriba



Mayúscula **S**: curva hacia atrás y luego hacia adelante



Minúscula **s**: curva hacia atrás y luego hacia adelante

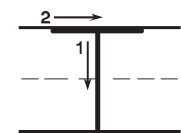

Mayúscula **T**: traza hacia abajo, levanta, traza de izquierda a derecha

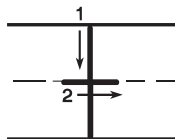

Minúscula **t**: traza hacia abajo, levanta, traza en el medio

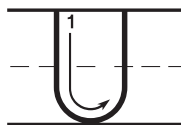

Mayúscula **U**: traza hacia abajo, curva a la derecha y sube hasta arriba

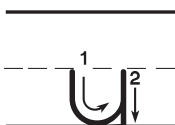

Minúscula **u**: traza hacia abajo, curva a la derecha, levanta, traza hacia abajo

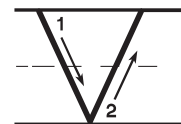

Mayúscula **V**: diagonal bajando de izquierda a derecha, diagonal hacia arriba

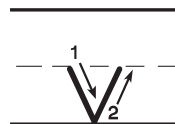

Minúscula **v**: diagonal desde el medio hacia abajo y desde abo hacia el medio

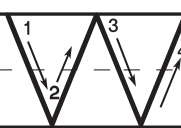

Mayúscula **W**: desde arriba diagonal bajando de izquierda a derecha, diagonal hasta arriba, repite

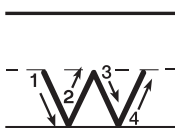

Minúscula **w**: desde el medio diagonal bajando de izquierda a derecha, diagonal hasta el medio, repite

Forming Letters (continued)

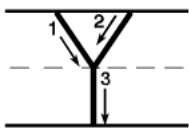

Uppercase **Y**: slant right down to the middle, lift, slide left down to the middle, pull down to the bottom

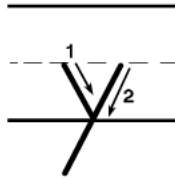

Lowercase **y**: slant right down, lift, slant left down

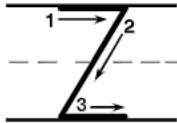

Uppercase **Z**: slide right, slant left down, slide right

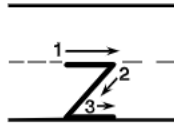

Lowercase **z**: slide right, slant left down, slide right

Trazado de las letras (continuación)

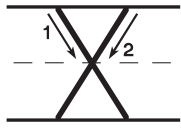

Mayúscula **X**: desde arriba diagonal bajando de izquierda a derecha, levanta, desde arriba diagonal bajando de derecha a izquierda

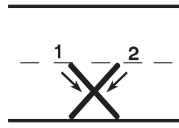

Minúscula **x**: desde el medio diagonal bajando de izquierda a derecha, levanta, desde el medio diagonal bajando de derecha a izquierda

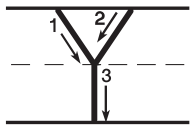

Mayúscula **Y**: desde arriba diagonal bajando de izquierda a derecha hasta el medio, levanta, desde arriba diagonal bajando de derecha a izquierda, desde la unión de las diagonales traza hacia abajo

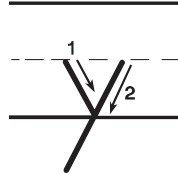

Minúscula **y**: desde el medio diagonal bajando de izquierda a derecha, levanta, desde el medio diagonal bajando de derecha a izquierda

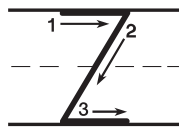

Mayúscula **Z**: traza de izquierda a derecha, diagonal de derecha a izquierda bajando, traza a la derecha

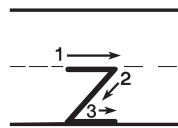

Minúscula **z**: traza de izquierda a derecha, diagonal de derecha a izquierda bajando, traza a la derecha

Name: _____ Date: _____

Handwriting Practice: Alphabet

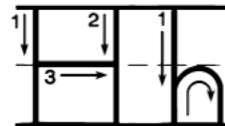
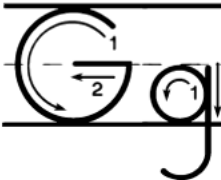
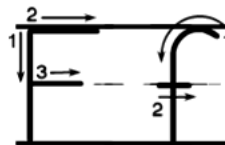
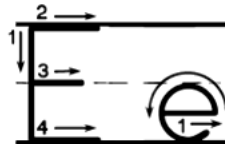
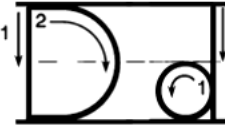
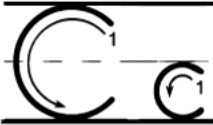
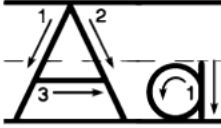

Name: _____ Date: _____

Handwriting Practice: Alphabet (continued)

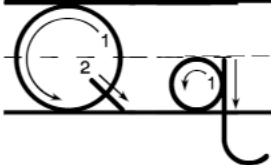
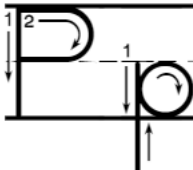
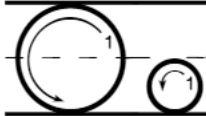
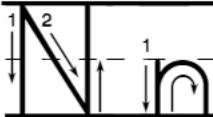
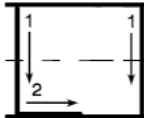
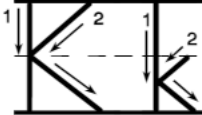
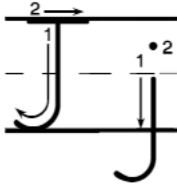
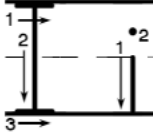

Name: _____ Date: _____

Handwriting Practice: Alphabet (continued)

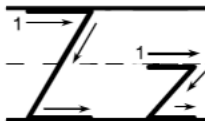
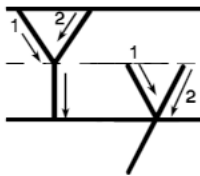
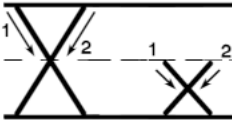
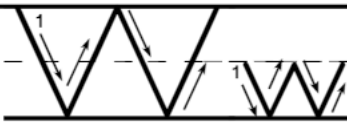
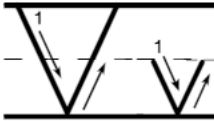
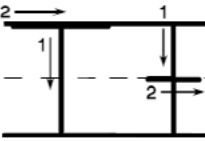

Name: _____ Date: _____

Handwriting Practice: Numerals

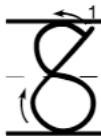
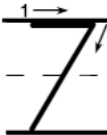
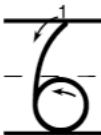
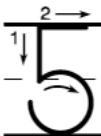
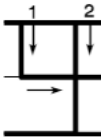
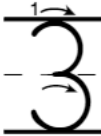
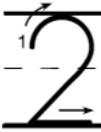
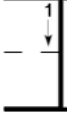
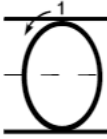

Handwriting practice paper with multiple sets of vertical lines. Each set consists of a solid line on the left, a dashed line in the middle, and a solid line on the right. There are four such sets across the page.

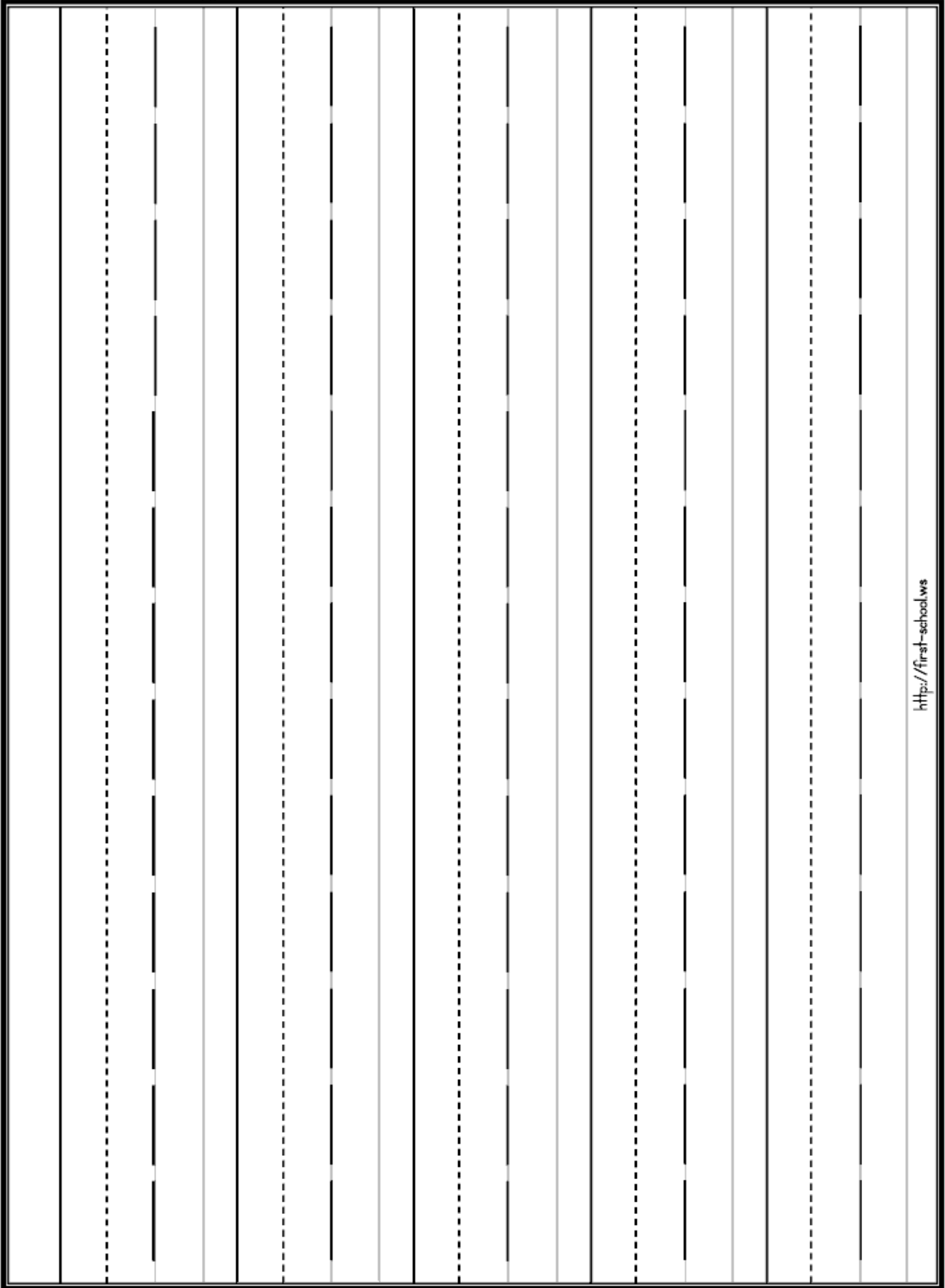
The page contains ten sets of handwriting practice lines. Each set consists of four horizontal lines: a solid top line, a dashed midline, a solid baseline, and a solid descender line. These lines are spaced evenly down the page to provide a guide for letter height and placement.

The page contains ten sets of handwriting lines. Each set is composed of three horizontal lines: a solid top line, a dashed middle line, and a solid bottom line. These lines are spaced evenly down the page to provide a guide for letter formation and alignment.

This form contains six sets of handwriting lines. Each set is composed of three horizontal lines: a solid top line, a dashed middle line, and a solid bottom line. These lines are intended to guide the placement of letters (ascenders, x-height, and descenders) for young learners.

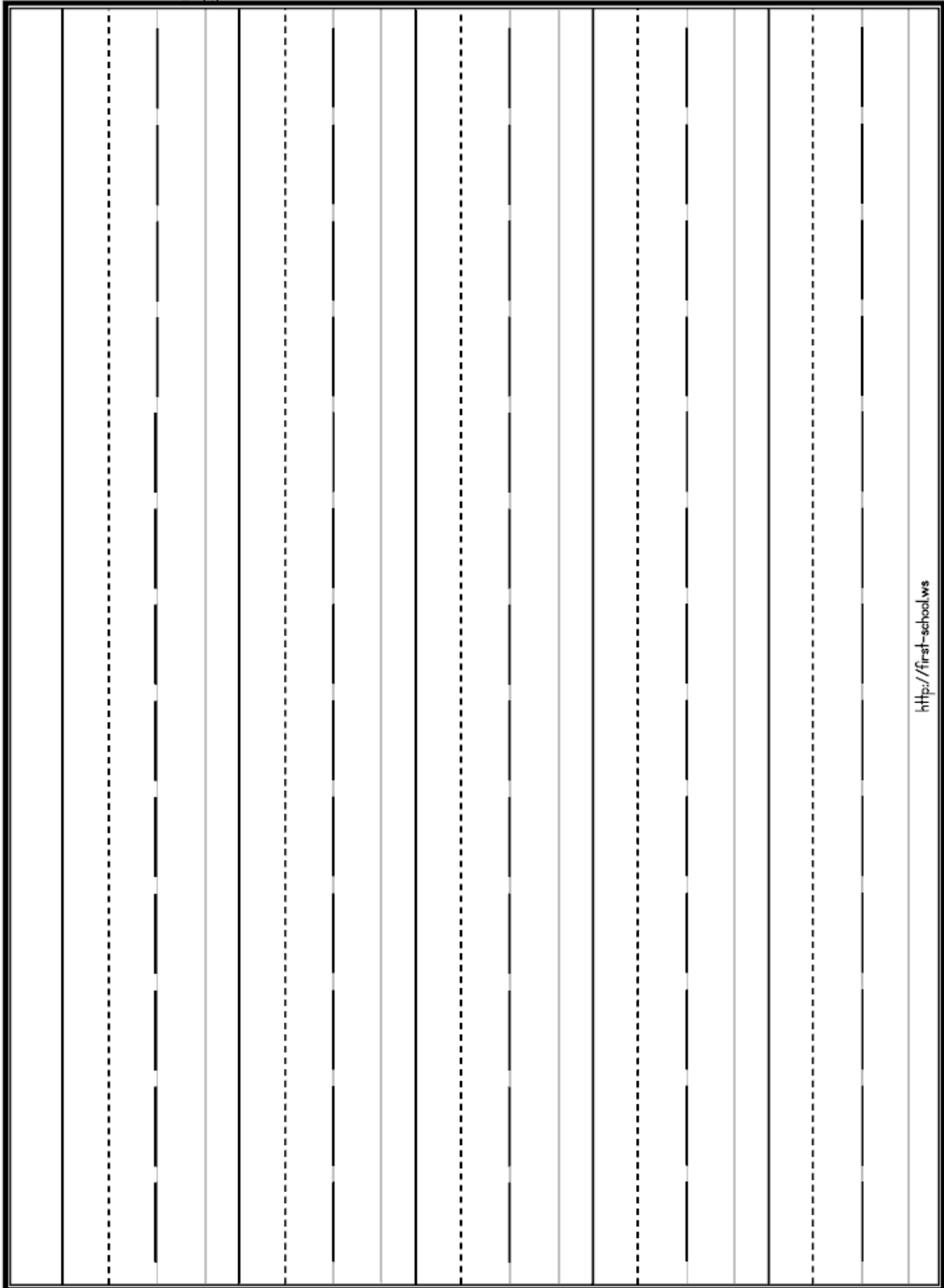

This page is a handwriting practice sheet. It contains 12 vertical columns, each designed for a single letter. Each column has three horizontal lines: a solid top line, a dashed midline, and a solid bottom line. The columns are arranged in a grid, providing a structured space for practicing letter formation.

The page contains ten sets of handwriting lines. Each set is composed of three horizontal lines: a solid top line, a dashed middle line, and a solid bottom line. These lines are spaced evenly down the page to provide a guide for letter formation.

The page is a handwriting practice sheet. It is divided into 12 vertical columns. Each column contains four horizontal lines: a solid top line, a dashed midline, a solid baseline, and a solid descender line. This layout is designed to help children learn letter formation and alignment.

--	--	--	--	--	--	--	--	--	--	--	--	--	--	--	--	--	--	--

Handwriting practice sheet with multiple columns of lines. Each column consists of a solid top line, a dashed midline, and a solid bottom line, providing a guide for letter height and placement. The columns are evenly spaced across the page.

A series of ten horizontal writing lines for handwriting practice. Each line set consists of a solid top line, a dashed midline, and a solid bottom line. The lines are evenly spaced and extend across the width of the page.

The page is a handwriting practice sheet. It features a large rectangular area with a black border. Inside this area, there are five horizontal rows. Each row is defined by two solid horizontal lines, one near the top and one near the bottom, with a dashed horizontal line in the middle. This layout is standard for teaching letter height and placement in primary grades.

The page contains ten sets of handwriting lines, each consisting of a solid top line, a dashed middle line, and a solid bottom line. These lines are arranged vertically down the page to guide letter formation.

Handwriting practice lines consisting of multiple rows of solid top and bottom lines with a dashed midline.

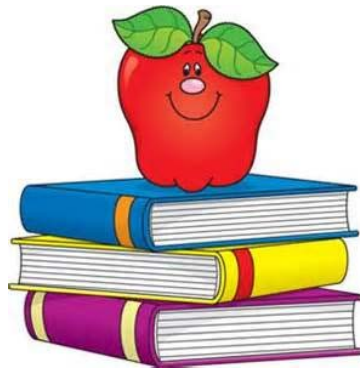

Phonics and High Frequency Words/Fonética y palabras de uso frecuente

Word Family Crossword

**Complete the crossword puzzle.
Write in the words for the pictures
shown.**

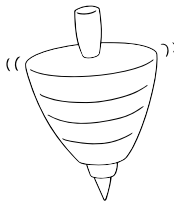

Word Bank

- mop
- hop
- top
- pop
- cop

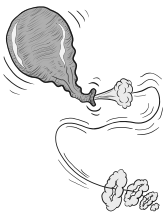



The Pop

**Read the poem and circle all the short o words.
Then write about something you sip.**

I sip a can of pop.

I like it!

I spill the pop.

I mop it.



I sip

I put my cap on me!



8

I Have It!



by Mickey Daronco

I have a map.
I set my map on my lap.
I look at the map.



6

I have a can.
I put my can in a pan.
The pan is not hot yet.

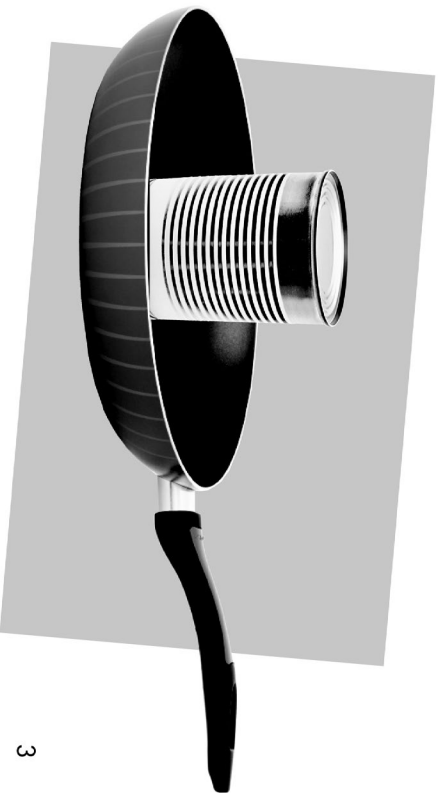

3

I have a tan cat.
My tan cat is fat.
My cat is on the mat.



I have a bat.
I put my cap
on my bat.



I have a big bag.
My bag is red.
My red bag has a tag.



I have a fan.
I put my fan in a van.
I will go home with it.



High-Frequency Words Graph

How many letters are in each word? Write the words below the graph. Color in the graph for each word.

he	has	little	play
-----------	------------	---------------	-------------

1				
2				
3				
4				
5				
6				

Pop and Tim

Read the story. Circle all the words with o. Then draw a picture with Tim and Pop.

Pop can see Tim.

Tim has a cap.

Tim can sit.

Tim can play a lot!

Play, Tim, play!

Pop can see Tim play.

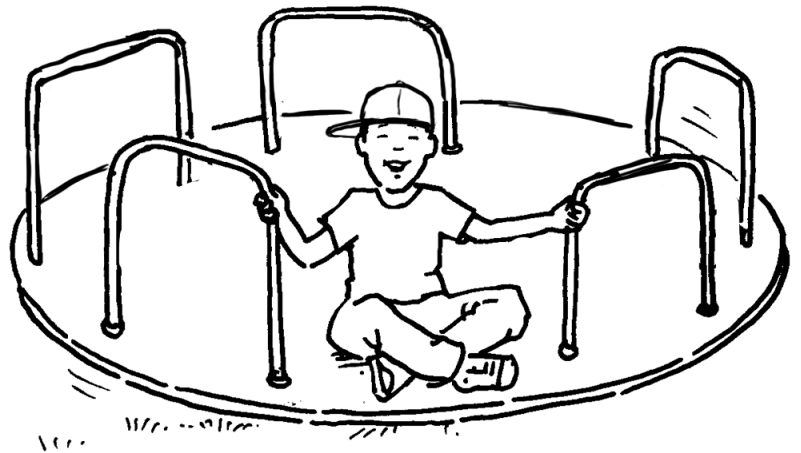

Pop has a mop.
The mop is on the tot.

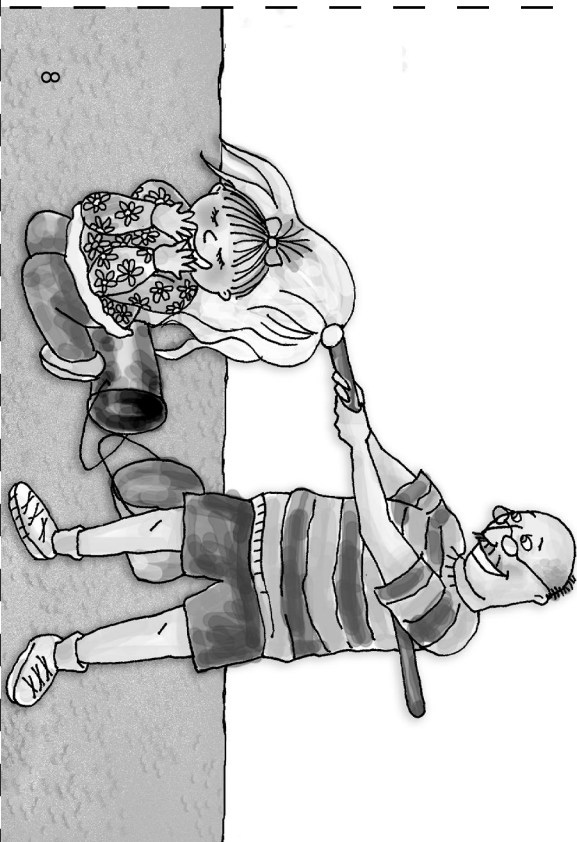

The pot is on Pop.



Pop

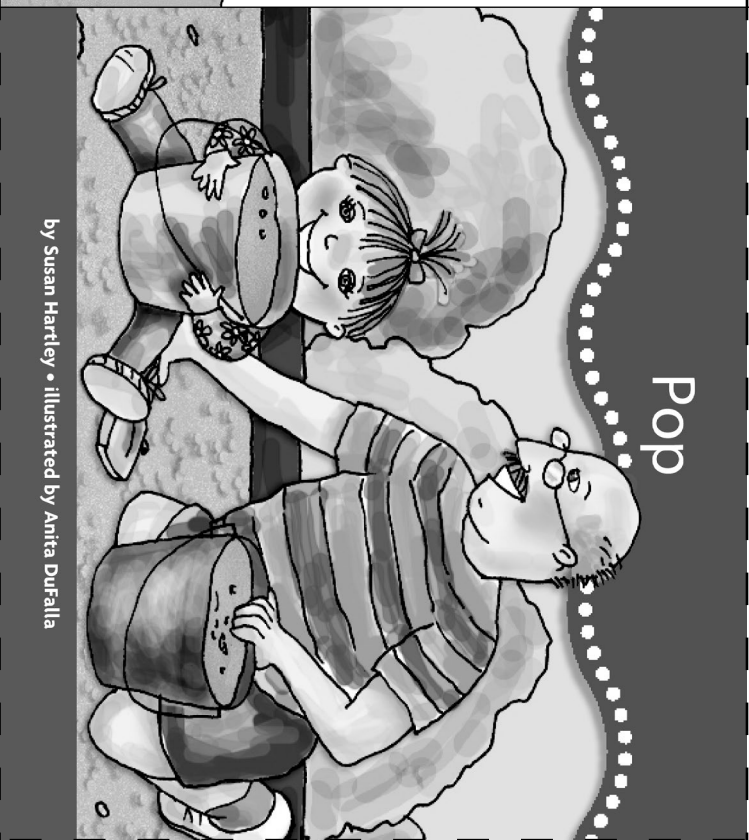

by Susan Hartley • Illustrated by Anita Dufalla

The tot is in the pit.



Pop is in the pit.

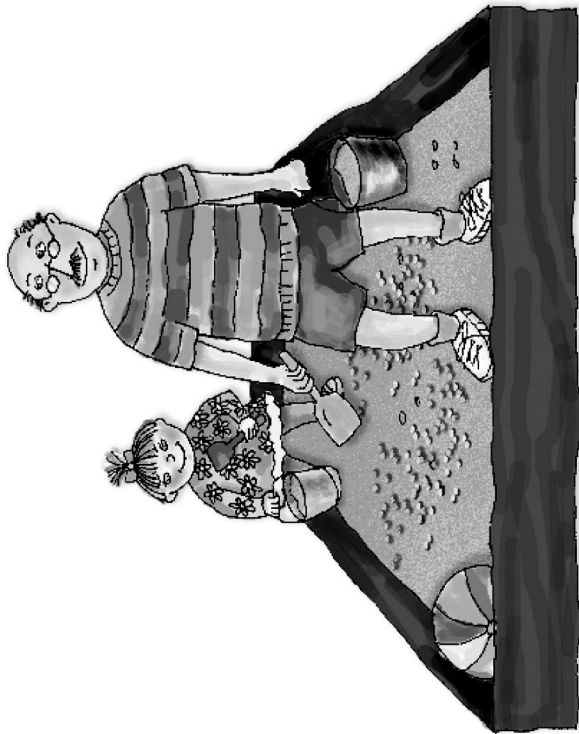

2

The pot is on the tot.



7

The tot has a tin pot.



4

Pop has a tan pot.



5

Tip the Cat

Read the poem.

Then complete the sentence about Tip the cat.

Tip is a cat.

He is not a little cat.

He is a fat cat!

Tip has a hat.

It is a top hat!



Tip is a

We Tip and We Dip!

Read the poem.

We tip and we dip.
 We go up and up.
 We dip and we tip!
 It is fun!

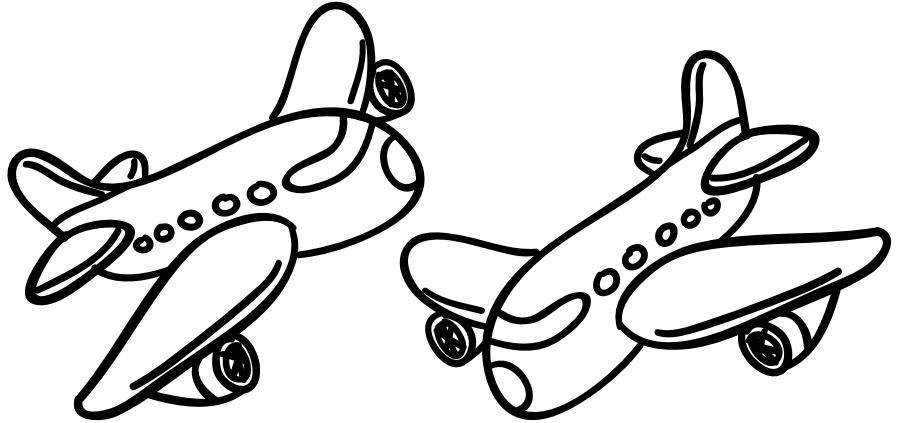

Now draw what happens next. Label your picture with *-ip* words.

cat

cop

fin

mat

mop

pin

pop

Sam

fan

Pam

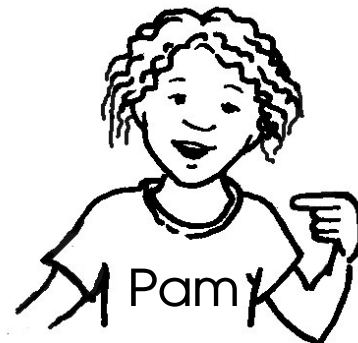
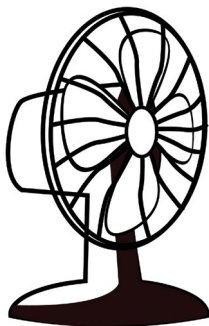
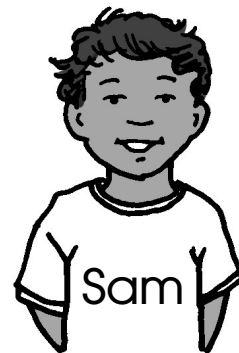
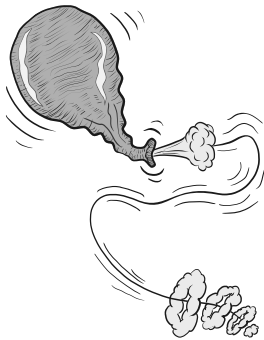
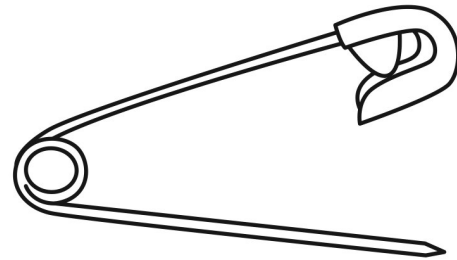
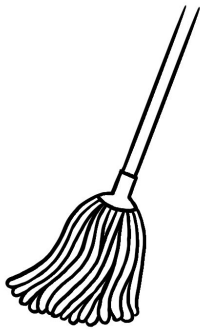
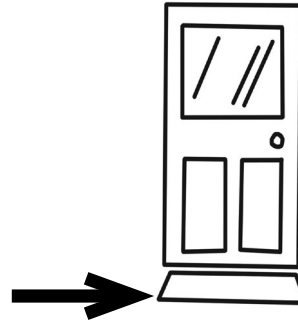
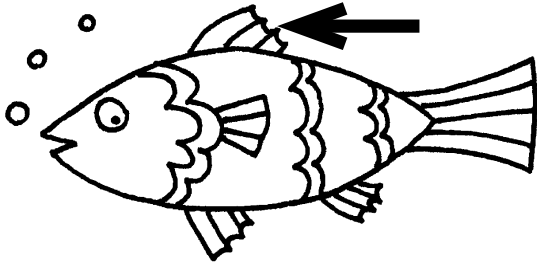

The Pig Digs

Read the story. Then look at the picture.

Dan and Deb have a pig.

She is a big pig.

She digs and digs in the mud.

The pig has fun.

She digs and digs!

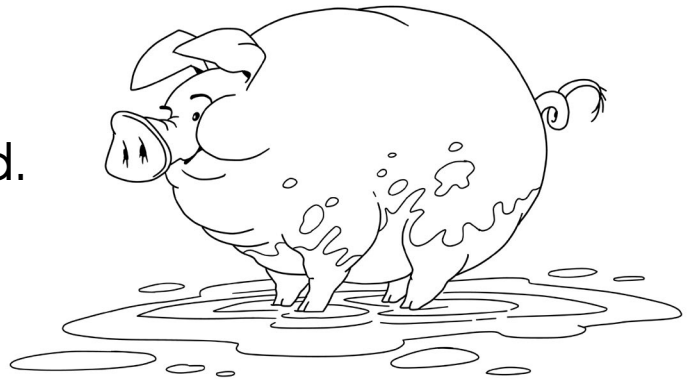

Now draw what happens next in the story.

Now write what happens next in the story.

Pip the Dog

Read the story. Then write what happens next.

Pip is a big dog.

Pip got in the tub.

Pip got wet.

Pip the dog had fun.

Can you see Pip go wag, wag, wag?

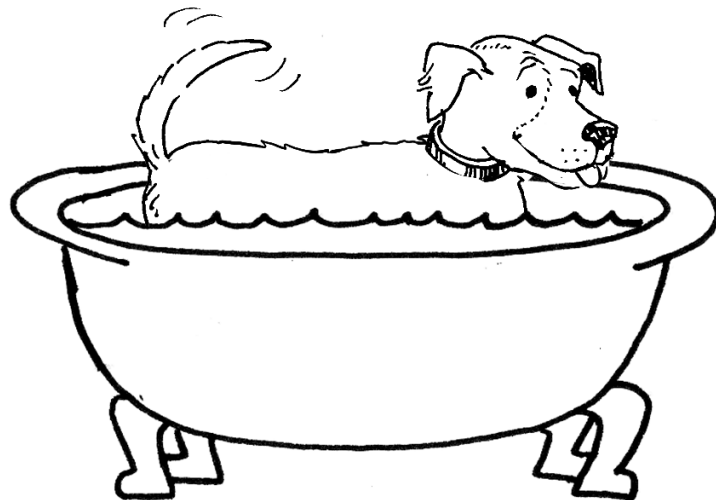

“Yes, I can,” Val said.
“I did it!”



8

“Look at me,” said Pam.
“I will dip it in.”



6

I Did It!



by Mickey Daronco

“Can I pin it?” said Jan.
Jan did not see it, but she
did put the pin in.

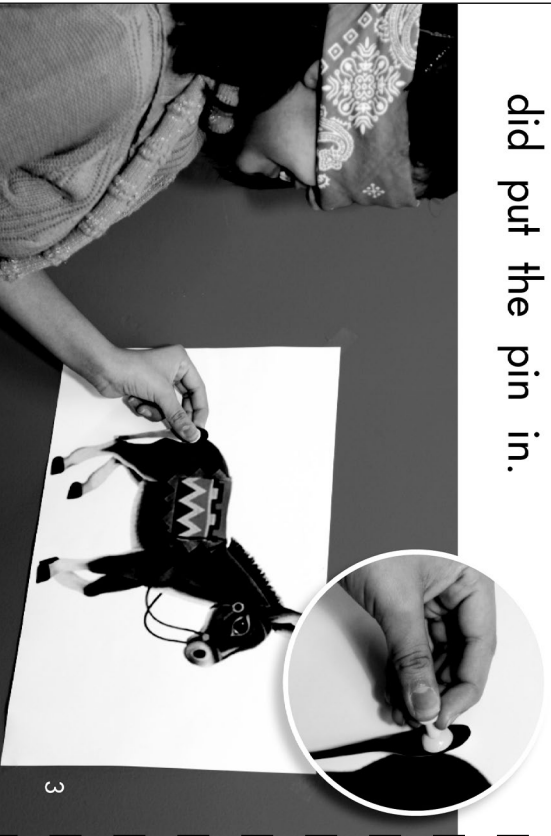

3

“Can I hit it?” said Ron.
Ron did hit it.
It went and went.



2

“Can I do it?” said Val.
“Can I fit it in?”

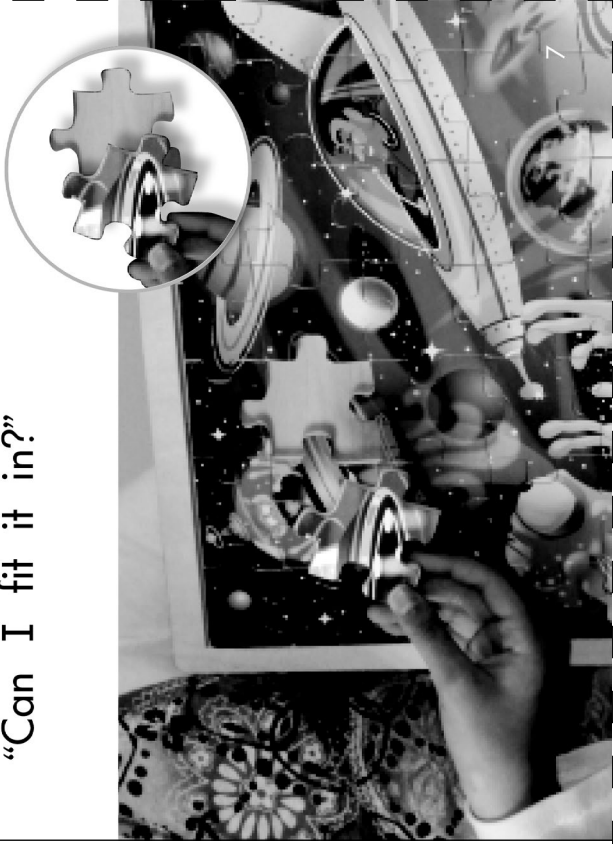

“It is not hot,” said Jan.
“I will have to zip up.”



“Will a hat be in
the red box?” said Jim.
“I will rip it and see.”



5

The Snack

Read the story. Circle words that begin with s.

Sniff, sniff!

What is that smell?

Ross has a snack.

It is egg on a bun.

A bit of egg slips off.

I get a snack!

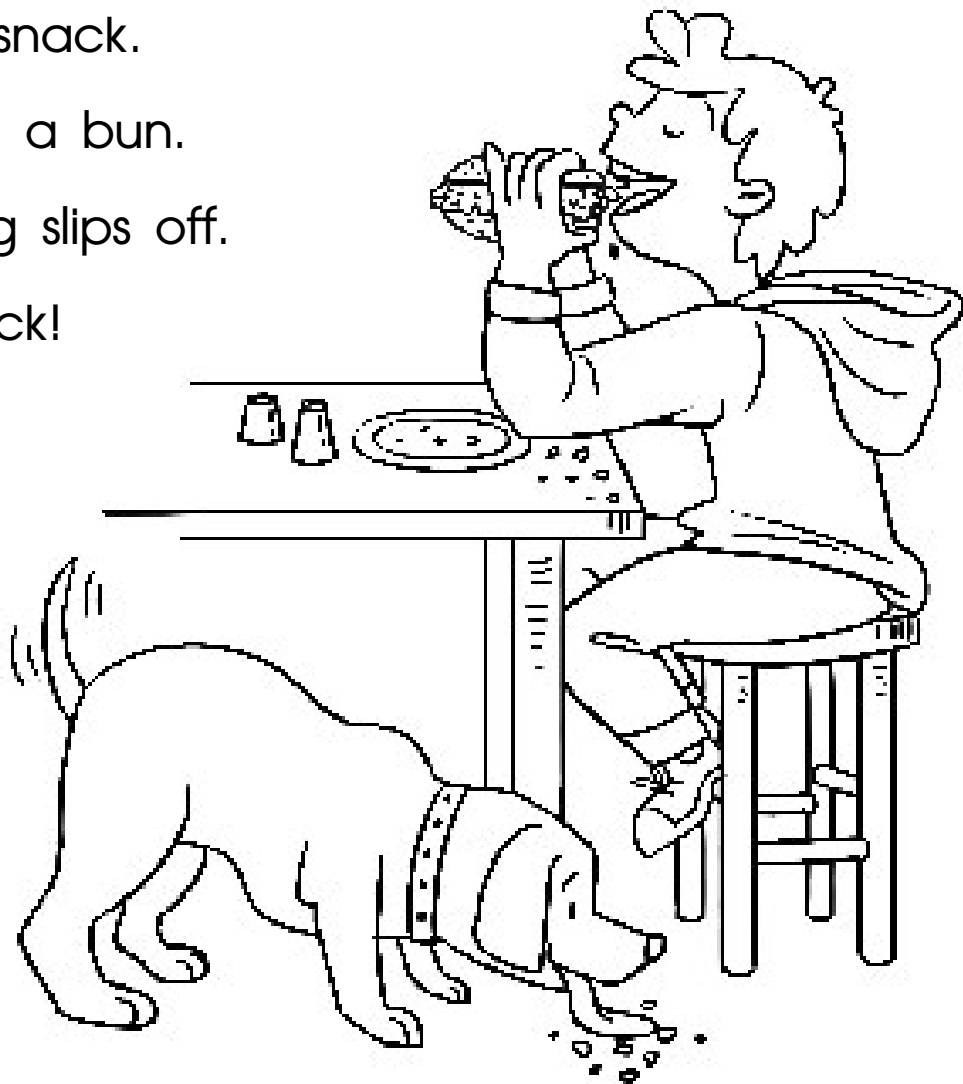

My Socks

Read the story. Then write a sentence to end the story.

I like socks.

I like socks with fuzz.

I like to cuff my socks.

But I will not sniff my socks.

My socks smell bad!



Handwriting practice lines consisting of solid top and bottom lines with a dashed middle line, repeated five times.

den

wig

dig

rip

dip

hip

wag

pig

wet

sip

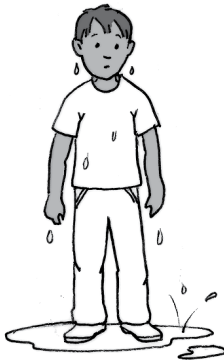
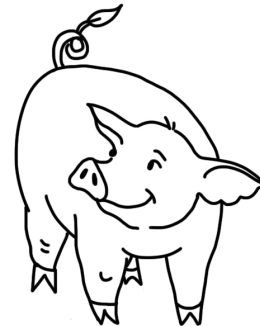
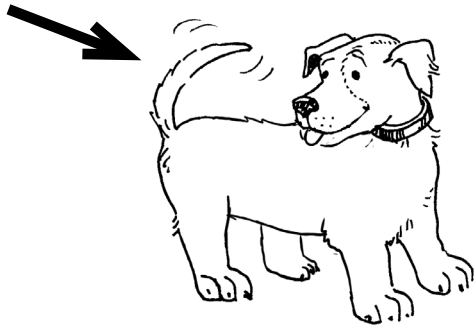
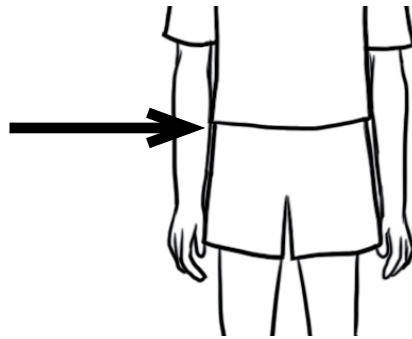
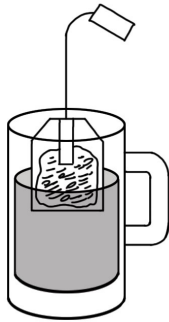
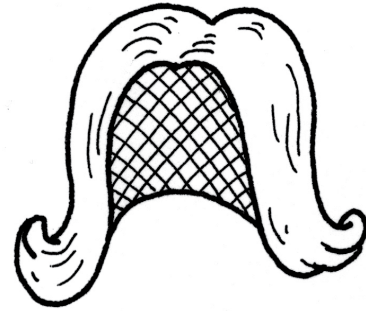
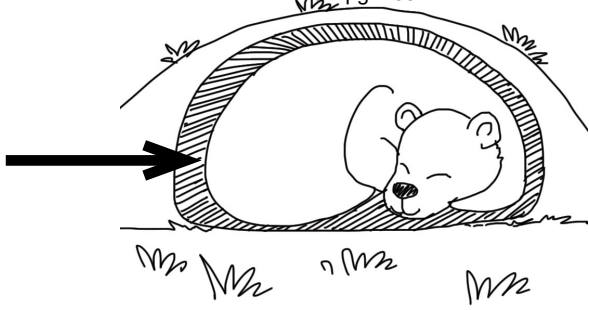

Sit by the Hill

Look at the picture. Label the things in the picture that make a short i sound. Use words from the box.

hill

stick

sit

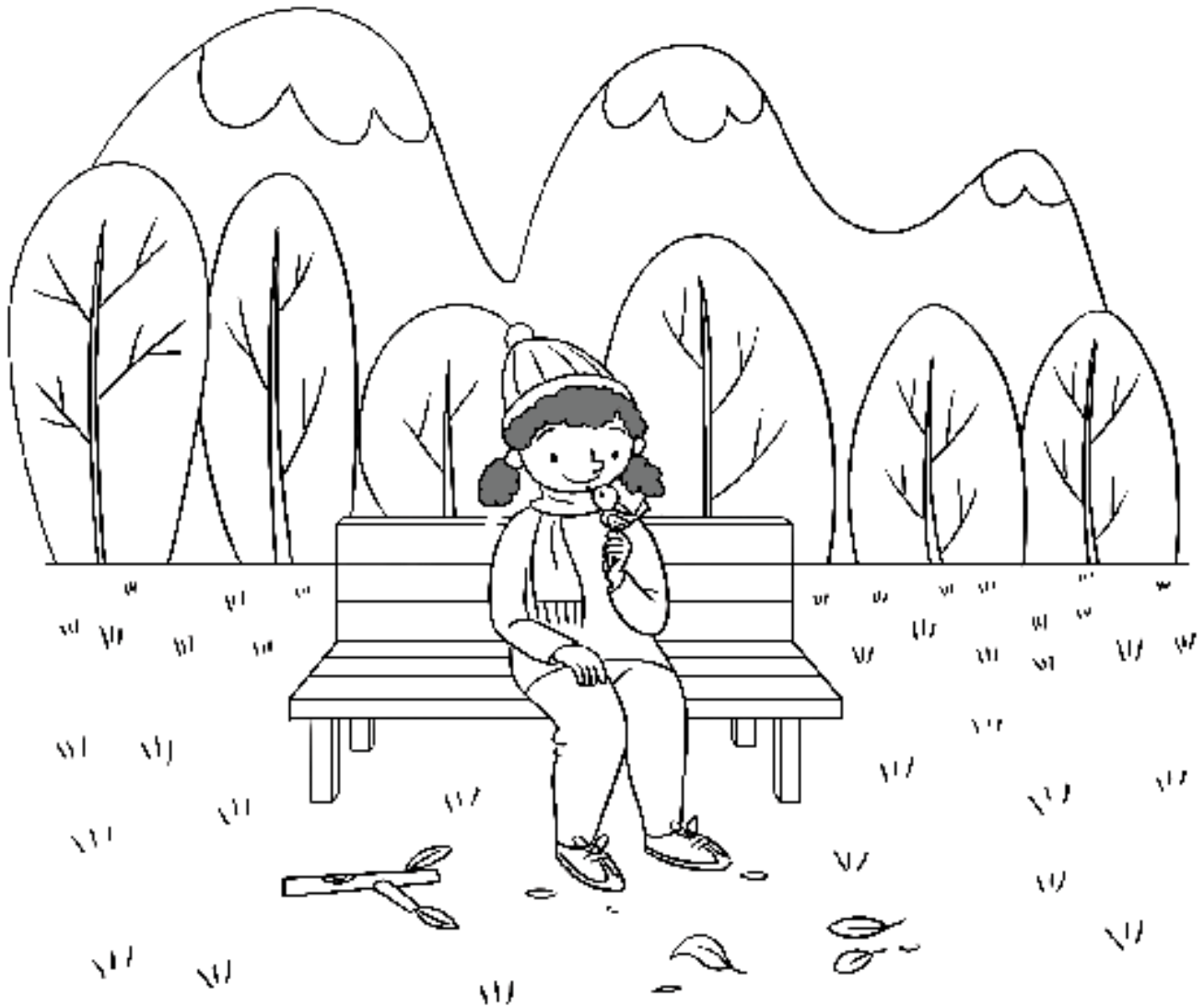

I See a Bug!

Read the story. Circle words with the short *u* sound.

I see a big, black bug.

The bug is on the rim of the cup.

Yuck!

I want the bug to get off of the cup.

I smack at the bug.

Buzz! Buzz!

The bug is off!

Now draw a picture of what happens next.

The hen is in the pen,
and the pup is in
the hut.



8

The hen and the pup met Ben.
“No, pup, no!” said Ben.



6

Mem the Hen



by Susan Hartley • Illustrated by Anita Dufalla

The pup ran at the pen.
Mem is not in the pen.



3

Mem is a tan hen.
Mem is in the pen.
The pup can see
the hen in the pen.



2

Ben has a net.
Mem is in the net.

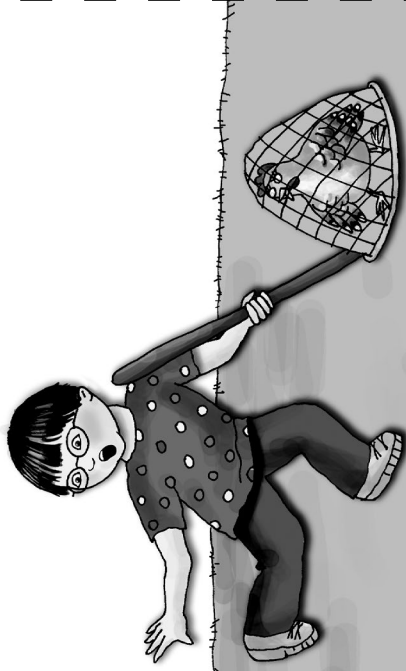

7

The tan hen ran and ran, and
the pup ran and ran.

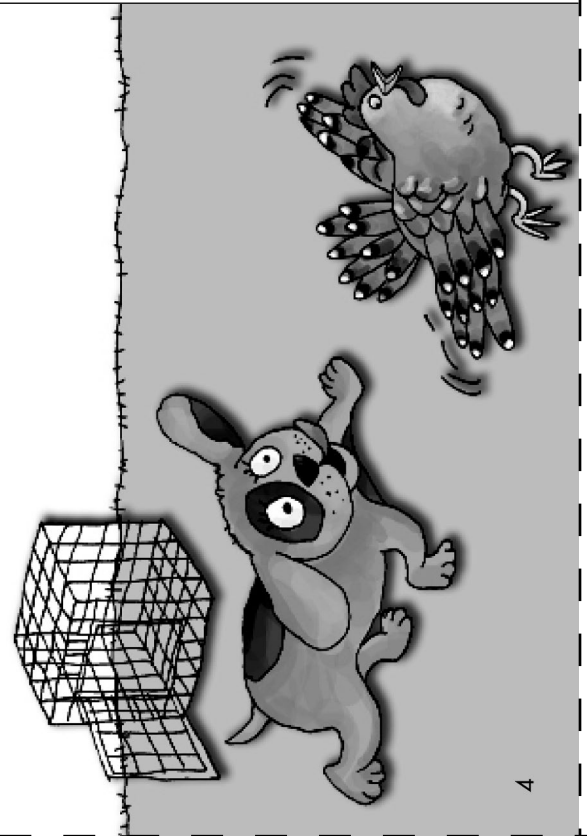

4

The pup and Mem met Pat.
Pat ran and ran.
The pup and Mem
ran and ran.



5

stick

snack

fan

hill

pan

map

pig

pin

zip

lip

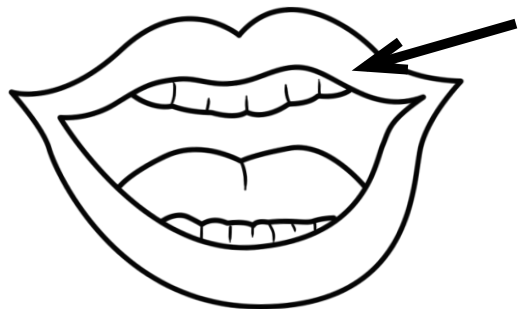
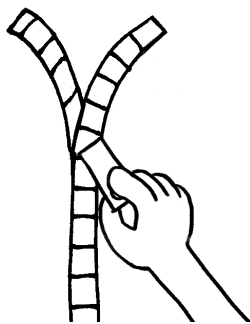
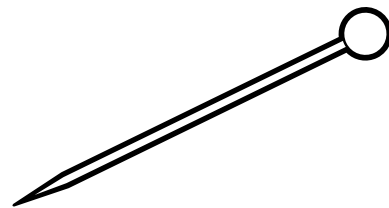
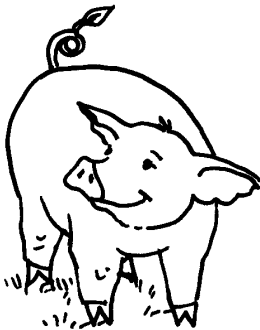
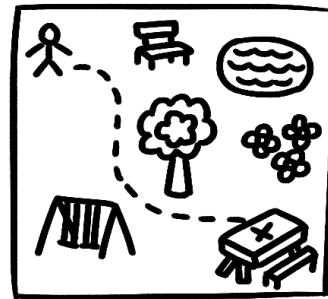
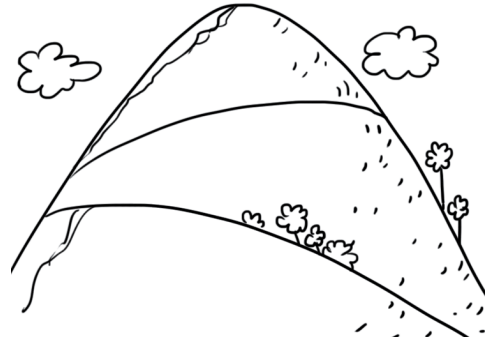
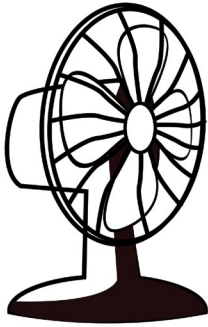
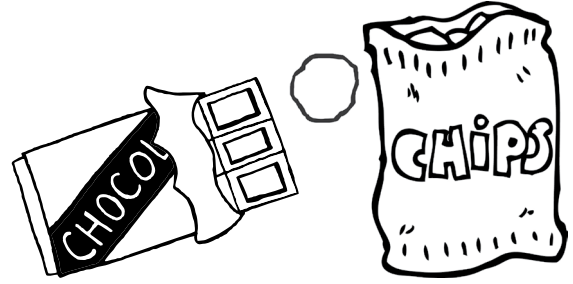
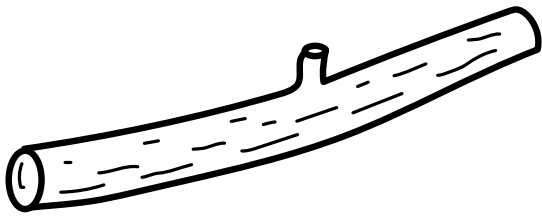

Word Family Ice Cream Cones

Read each word. Write or place the scoops of ice cream on the correct word family cones.

bet
hop
met
get
stop

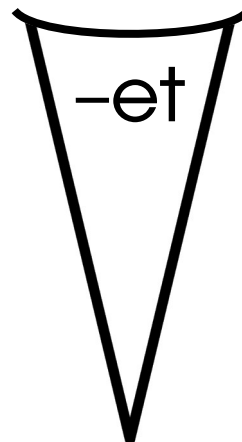
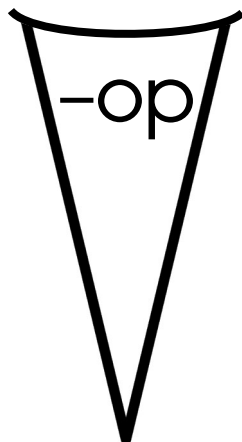

pet
pop
mop
set
top

High-Frequency Words Graph

How many letters are in each word? Write the words below the graph. Color in the graph for each word.

play	no	has	little
-------------	-----------	------------	---------------

1				
2				
3				
4				
5				
6				

<hr/>	<hr/>	<hr/>	<hr/>
<hr style="border-top: 1px dashed;"/>	<hr style="border-top: 1px dashed;"/>	<hr style="border-top: 1px dashed;"/>	<hr style="border-top: 1px dashed;"/>
<hr/>	<hr/>	<hr/>	<hr/>

Can I Get a Pet?

Read the story.

Can I get a pet?

A frog is fun, I bet!

A frog can hop and jump.

A frog likes to get wet.

A frog can snack on bugs.

I will be glad to get a

frog as a pet.

Now draw a picture of the pet you want.

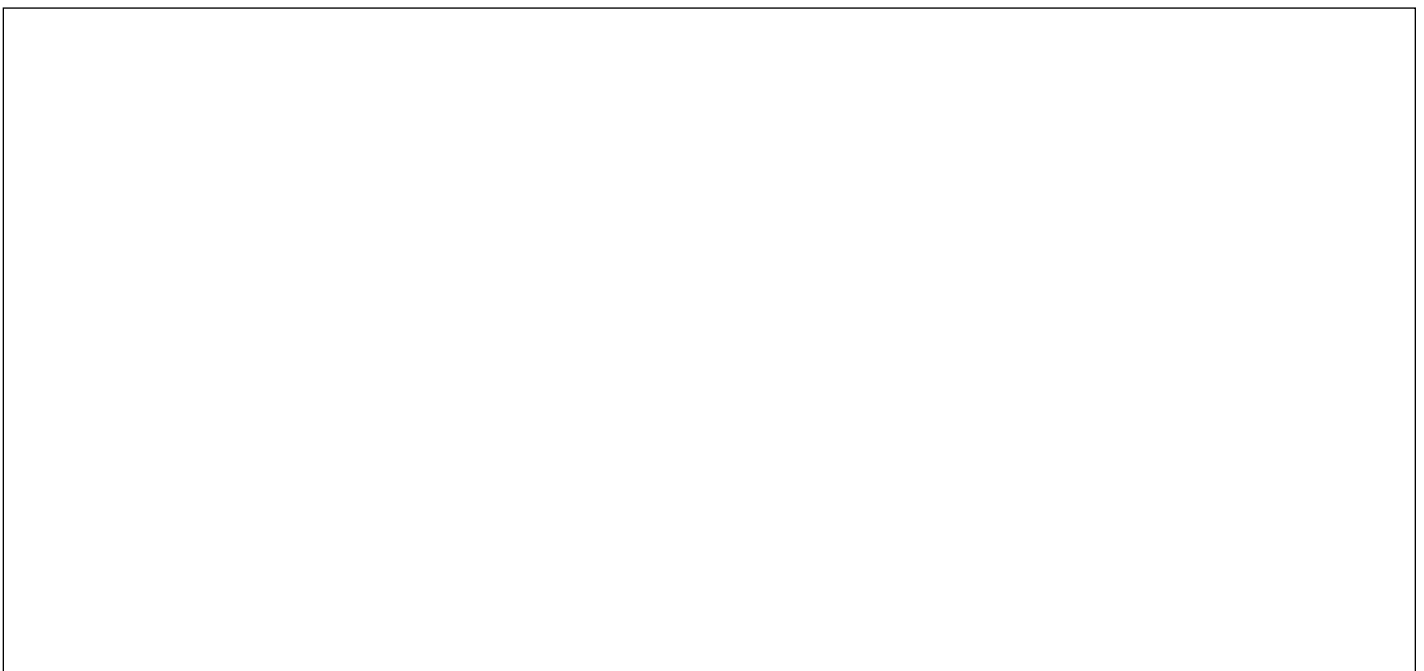

hen

pen

well

web

fox

jog

mop

stop

jug

nut

bug

pup

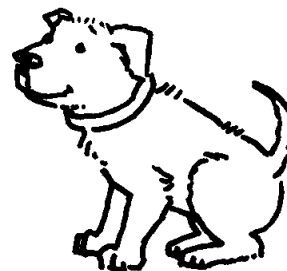
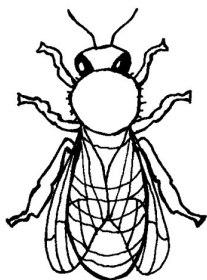
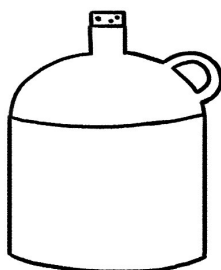
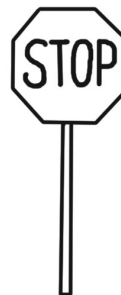
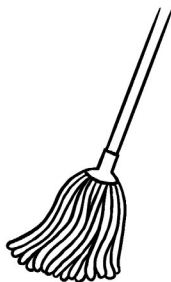
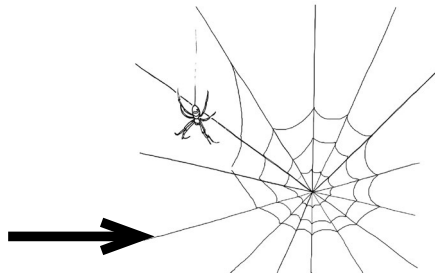
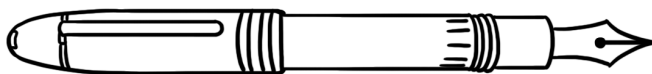
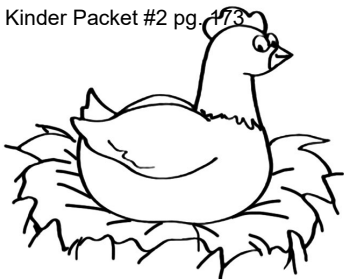

The Little Cub

**Read the poem. Then look at the picture.
Write two or three sentences to tell what you see.**

A little cub sat on a log.
I said, "Have we met?"
The cub said, "Not yet!
Do you want to play?"

"Yes," I said.
So I play with the cub
and give him a hug.

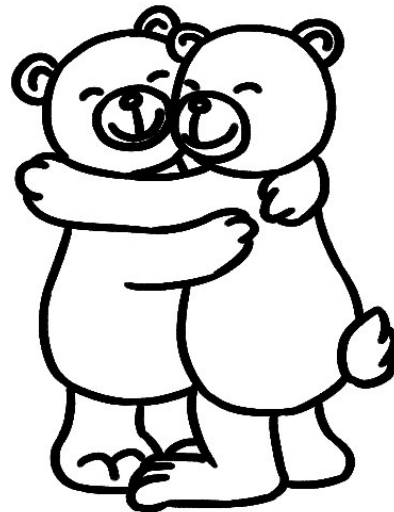

I can sit
in the hot sun.
I like the sun a lot!



8

I can get fit
in the hot sun.
I can hit with my bat.

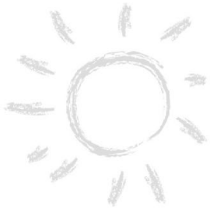

6

The Hot Sun

by Mickey Daronco



It is fun to dig
in the hot sun.
I fill my red tub.



3

I like the hot sun.
I can do a lot
in the sun.

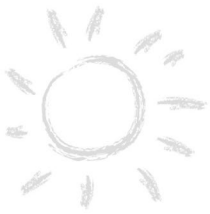

2

Then I run and run.



7

It is fun to get wet
in the hot sun.
I go in for a dip.

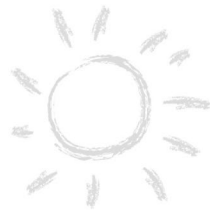

4

I can be on a mat
in the hot sun.
I rub it in. I do not
want to get red.



5

Name: _____

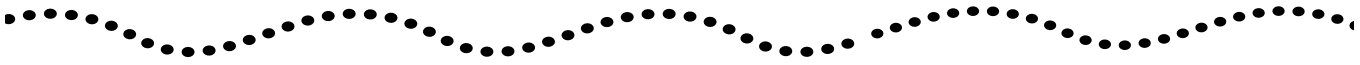

Word Lists

Word Lists

<p>Day One</p> <p>will</p> <p>did</p> <p>hub</p> <p>nap</p>	<p>Day Two</p> <p>let</p> <p>lug</p> <p>rug</p> <p>lap</p>
<p>Day Three</p> <p>lab</p> <p>bib</p> <p>nut</p> <p>lid</p>	<p>Day Four</p> <p>met</p> <p>cub</p> <p>ran</p> <p>lip</p>



Name: _____

Sounds Like Lion



Sounds Like Lion

Teacher Directions: Have students find and color all the things in the picture that start with /l/.

Name: _____

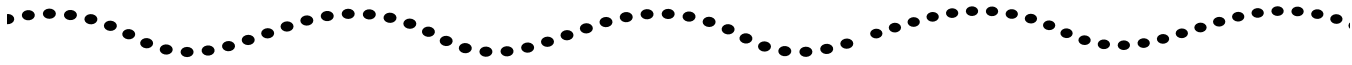

Match the Sounds

Match the Sounds

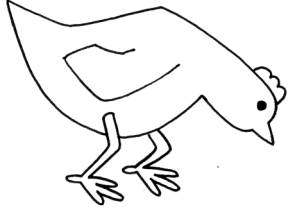
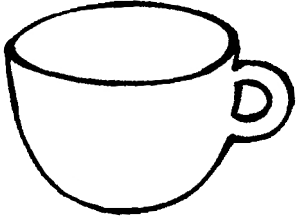
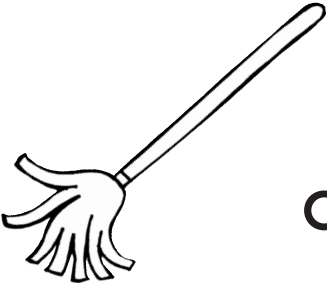
 e		
 u		
 o		

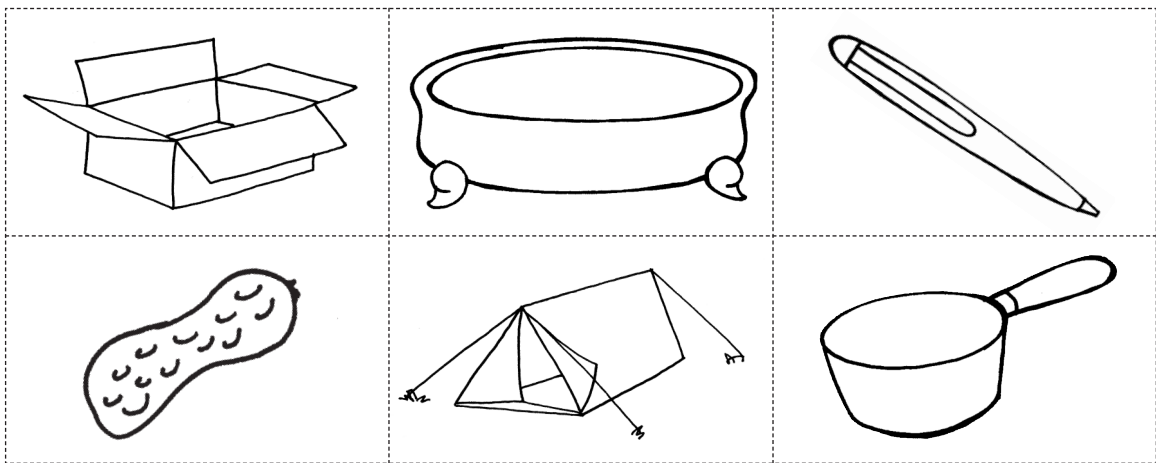

Teacher Directions: Have students cut out the boxes at the bottom of the page and paste each picture next to the letter that stands for the middle sound.



Name: _____

Name the Picture

10

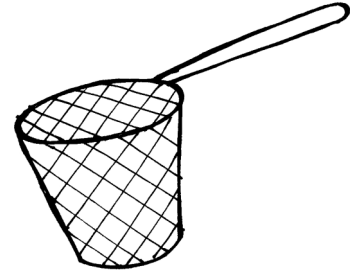

ten

tan

get

hen

man

pet

pen

ran

net

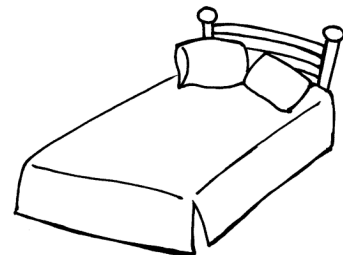
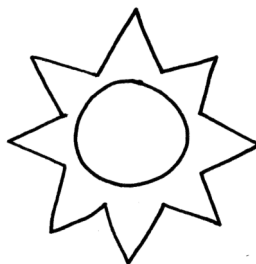
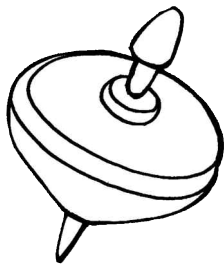

hop

bun

bed

mop

sun

led

top

run

red







Name the Picture

Teacher Directions: Have students say the picture name and circle the word that names the picture.

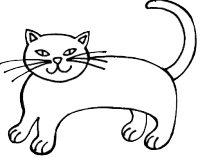
Name: _____

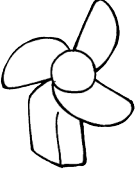

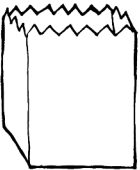
Draw to Match

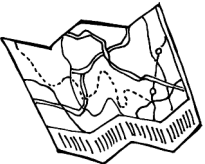
	<p>cat</p>	<p>can</p>
	<p>pet</p>	<p>pen</p>
	<p>fan</p>	<p>fat</p>
	<p>pat</p>	<p>pan</p>
	<p>bag</p>	<p>bat</p>
	<p>hen</p>	<p>hem</p>
	<p>mat</p>	<p>map</p>

Draw to Match

Parent Directions: Have your child circle the word that names the picture.



Name: _____

Concentration

Concentration

go	go	my
my	look	look
he	he	come
come	here	here

Parent Directions: Have your child cut out the word cards and place them facedown. Play a game using the cards. One player turns over two cards at a time and reads the words. If the words match that player keeps the cards.

Name: _____

Word Lists

Word Lists

Day One

wet

bog

jet

Len

Day Two

job

jam

can

win

Day Three

set

top

jet

Jim

Day Four

job

tin

map

Jen

Name: _____

Sound Search



Sound Search

Teacher Directions: Have students find and color all the things in the picture that start with /j/.

Name: _____

Beginning Sounds

Beginning Sounds



j b p

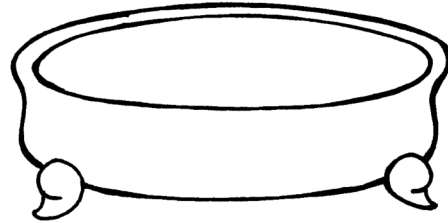

j b t



l d g



n m p

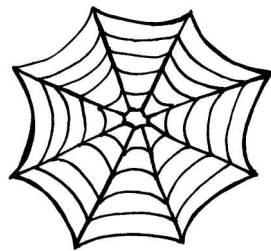

b l w

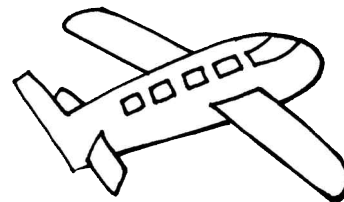

t j r

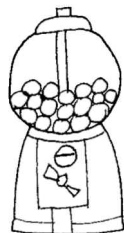

g m r

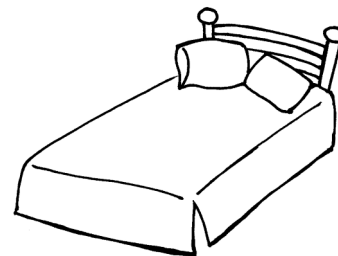

d j b

Teacher Directions: Have students say the name of each picture and circle the letter that stands for the beginning sound. Then have them color the pictures that start with the same sound as the word *jump*.

Name: _____



Rhyme Time

Rhyme Time

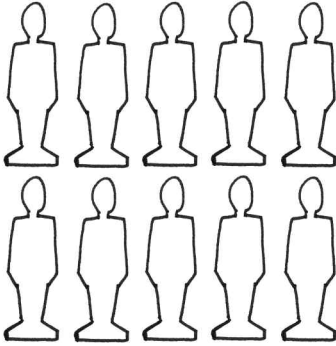

dog/log

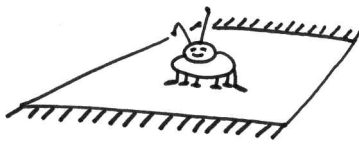

cat/bat

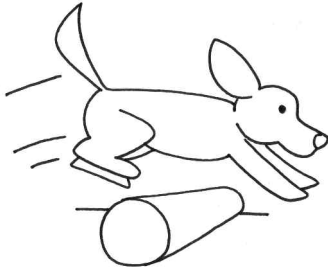

bug/rug

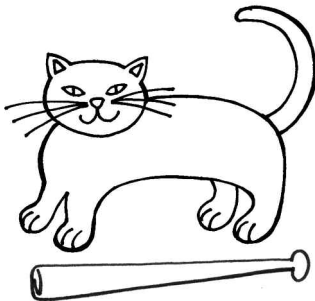

ten/men

Teacher Directions: Have students draw a line from a picture to the rhyming words that tell about it.



Name: _____

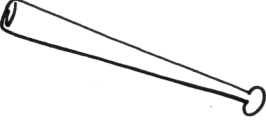
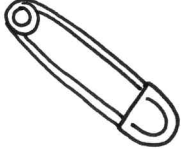
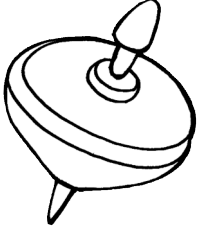
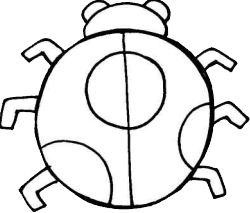
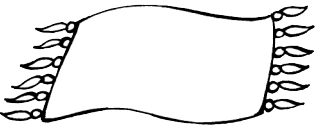
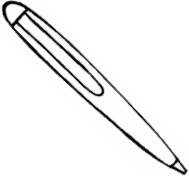

Listen for the Sound

	<p>bag bat</p>
	<p>pit pin</p>
	<p>top tot</p>
	<p>but bug</p>
	<p>rub rug</p>
	<p>pen pet</p>

Listen for the Sound

Parent Directions: Have your child say the name of the picture and listen for the sound at the end of each name. Then have your child circle the word that names the picture.



Name: _____

Word Puzzle

Word Puzzle

put the cannot want no come has see

			p		t				
						h			s
			c						
			n						
w									

Parent Directions: Have your child read the words aloud. Then have your child fill in the words in the puzzle.